

2012 Atlas Copco MT6020 Underground Dump Truck TH070



Make	Atlas Copco		Model	MT6020		
Year	2012	Hours	33205		As at	04/10/2021
Mileage				km	As at	
Serial/VIN	AVO12X283			Engine Serial		
Details	2012 Atlas Copco MT6020 Underground Dump Truck Asset TH070. See more component hours details in the GES Equipment report on the auction page for this asset. Offered for sale via online auction in "As Is" condition, running to drive on to buyers transport ex site Pinjarra, WA. Australia.					
Asking price	AUD	Under review - call for pricing				
Ex site	Australia, Western Australia, Pinjarra					

Service history	See the component hours data at the end of this report.
------------------------	---

**For further details, to make an offer or book an inspection, contact
Global Equipment Solutions on Office: 08 9201 1142**











TH070 COMPONENTS

Machine Type	Last Changed	Component Hours	Hours remaining until change out	Lifespan										Next Change	Change out Interval
				10%	20%	30%	40%	50%	60%	70%	80%	90%	100%		
MT6020															
Serial #															
AVO 12X 283															
Frame Hours															
33205															
ENGINE	22627	10578	1422											34627	12000
TRANSMISSION	19339	13866	-3866											29339	10000
UPBOX	26116	7089	2911											36116	10000
UPBOX COUPLING	19339	13866	-3866											29339	10000
DROPBOX	21370	11835	-1835											31370	10000
FRONT DIFF	19339	13866	6134											39339	20000
REAR DIFF	24112	9093	10907											44112	20000
WHEEL RIMS	19340	13865	2135											35340	16000
POS 1	19339	13866	2134											35339	16000
POS 2	25910	7295	8705											41910	16000
POS 3	19339	13866	2134											35339	16000
POS 4	19339	13866	2134											35339	16000
TURBO LINES	24985	8220	-220											32985	8000

Specifications

Capacities		Motion times	
SAE regulations		Dump box	
Tramming capacity	60 000 kg	Dumping	15 seconds

Engine

- Cummins.....QSK19-C760, Tier 1/Stage I A
- Power Rating at 2100 rpm..... 567 kW/760 hp
- Maximum torque at 1300 rpm.....3 084 Nm
- MSHA Part 7 ventilation rate TBA
- Ventilation particulate index TBA
- Rock Tough purifier and silencer.
- Dry type air cleaner.
- Exhaust heat protection.
- Remote engine oil drain.
- Cooling package with flat, round, mechanical radiator.

Transmission and converter

- Planetary, automatic 6 speeds forward/2 speeds reverse with integral single stage converter with automatic lock up.
- Allison.....M6610AR
- Up box: Power transmitted through a 1:1 gear ratio box.
- Drop box: Power transmitted through a 1:1 gear ratio box.

Axles

- Kessler 111
- Conventional front and rear differential.
- Front-axle oscillating suspension "A" frame with hydraulic suspension cylinders and accumulator cushioning.
- All wheel drive.

Brakes

- Fully enclosed, force cooled, multiple wet discs at each wheel end.
- Service/parking/emergency brakes..... SAHR
 - Hydraulic retarder.



The MT6020 is standard equipped with a rear vision camera. A small detail, but definitely worth viewing - is the standard equipped camera for improved operator's visibility.

Tyres

- Tubeless, steel radial, lug tread design for underground mine service.
- Dimensions 35/65, R33*
- * As applications and conditions vary, Atlas Copco recommends that the user consults with tyre suppliers to obtain the optimum tyre selection.

Suspension

- The suspension is a gas-hydraulic system for improved operator comfort and vehicle handling while minimizing frame stress.
- Suspension, max:105 mm
 - Individual self leveling suspension.

Operator's compartment

- Forward facing seat.
- Cabin; MSHA-ISO ROPS/FOPS approved.
- Grammer seat with retractable seat belts.
- Airconditioner.
- Trainer seat.
- Back up video monitor.

Hydraulic system

- System pressure 20.7 MPa
- Hydraulic tank capacity 238 litres
- Filtration, return line 4.0 µm
- Heavy duty gear type pumps.
- Cylinders diameter:
 - Steer cylinders (2) 160 mm
 - Dump cylinders (2) 177.8 mm
 - Suspension cylinders (2) 125 mm

Electrical system

- Voltage, system start & accessories 24 V
- Alternator, high output 100 A
- Hydraulic warning system; temperature, hyd. oil level.
- Rock Tough projection lights.
- Isolation switch lockout.

Fuel

- Fuel tank capacity 644 litres
- Fuel consumption, full load 67 litres/hour
- Fuel filtration 10 µm
- Anti-siphon fuel supply.

Turning radius

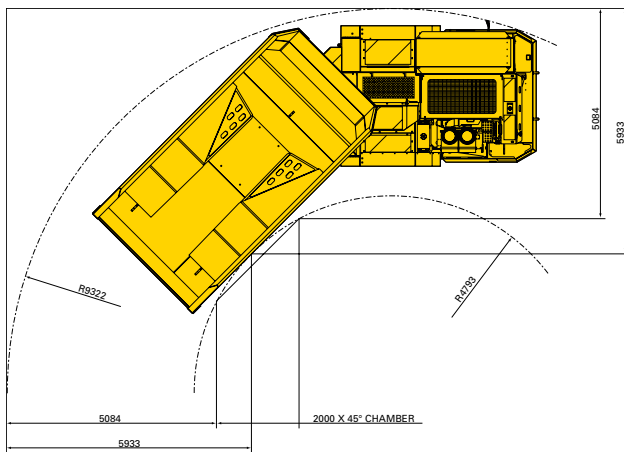

Recommended drift size

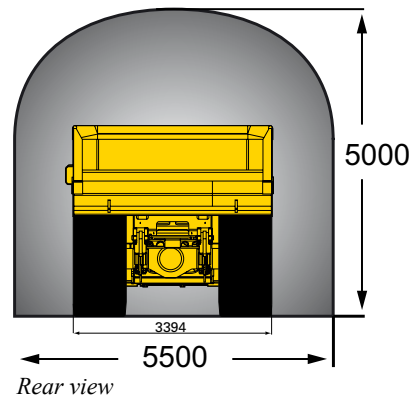

- Turning angle +/-42.5°.
- Dimensions shown are based on standard vehicle configuration with 27 mm tyre deflection.
- All dimensions are shown in millimetres.

Grade performance

NB. 3% rolling resistance assumed. Actual performance may vary depending on the application.

Standard configuration, box empty

Percent grade	0.0	2.0	4.0	6.0	8.0	10.0	12.0	14.0	16.0	18.0	20.0
Ratio					1:12	1:10	1:8	1:7			1:5
1st gear (km/h)	6.4	6.4	6.3	6.3	6.3	6.3	6.3	6.3	6.3	6.3	6.3
2nd gear (km/h)	9.5	9.5	9.4	9.4	9.4	9.4	9.3	9.3	9.3	9.3	9.2
3rd gear (km/h)	12.6	12.6	12.5	12.5	12.4	12.4	12.4	12.3	12.3	12.2	12.2
4th gear (km/h)	18.3	18.2	18.2	18.1	18.0	17.9	17.8	17.7	17.6	17.5	17.1
5th gear (km/h)	25.2	25.1	24.9	24.7	24.5	24.3	24.2	23.2	21.2		
6th gear (km/h)	37.5	37.1	36.7	36.3	35.6	30.9					

Standard configuration, box loaded

Percent grade	0.0	2.0	4.0	6.0	8.0	10.0	12.0	14.0	16.0	18.0	20.0
Ratio					1:12	1:10	1:8	1:7			1:5
1st gear (km/h)	6.3	6.3	6.3	6.2	6.2	6.2	6.2	6.1	6.1	6.1	6.0
2nd gear (km/h)	9.4	9.3	9.3	9.2	9.2	9.1	9.0	9.0	8.3	7.3	
3rd gear (km/h)	12.5	12.4	12.3	12.2	12.1	11.9	10.6				
4th gear (km/h)	18.1	17.9	17.6	17.2	13.5						
5th gear (km/h)	24.8	24.3	22.5								
6th gear (km/h)	36.5	31.7									

Optional equipment

Main frame

- Wheel chocks and chock brackets.
- Tele dump

Ergonomic

- KAB 555 seat W/retractable seatbelts.
- Heater

System

- Ansul dual bottle fire suppression with Engine kill.
- Electric hydraulic tank fill pump.
- Dual fuel filter.

- Lincoln auto lube with timer.
- Wiggins fast fuel-, transmission-, hydraulic- oil fill.

Electrical system

- Amber strobe light - power on.
- Load lights.
- Side light opposite operator.
- Tail and brake lights.
- Turn signals, front and rear.
- 24/12 V power converter.
- Loading camera.
- Battery heater, 120 V.
- Block heater, 120 V.
- Hydraulic oil heater, 120 V.

- Engine oil heater, 120 V.

- Diesel Filter with heater and water separation (7 micron).
- Fire extinguisher (20 LB)

Drive train

- Neutral brake apply.

Controls and instruments

- Blockout 5th and/or 6th gears.
- Emergency steering- accumulator type.
- Extended data gauge package.

Power unit

- Epoxy coated radiator.

Documentation

- LinkOne parts catalogue, CD.
- Parts and service manual - plasticised.

Parts kit

- 1 000 hour consumables.

Other

- Tool box.

Dump boxes

Dump box data		STD			
Material density (t/m ³)	1.8	2.0	2.2	2.4	
Volume, SEA struck (m ³)	30.4	26.6	24.1	21.7	
Volume, Semi-heaped (m ³)	33.3	29.7	27.3	25.0	
Volume, SAE heaped (m ³)	36.3	32.8	33.4	28.2	
Width, dump box (mm)	W	3 440	3440	3440	3440
Dump position: Box height, max (mm)	H1	6909	6842	6750	6689
Tramming position: Dump box height (mm)	H2	3462	3263	3122	2993
Dump position: Clearance (mm)	C	471	471	471	471

Dimensions and weights

Approximate net weight.....43 900 kg
 Axle load, front end29 700 kg
 Axle load, back end.....14 200 kg

Standard equipped vehicle with empty box.

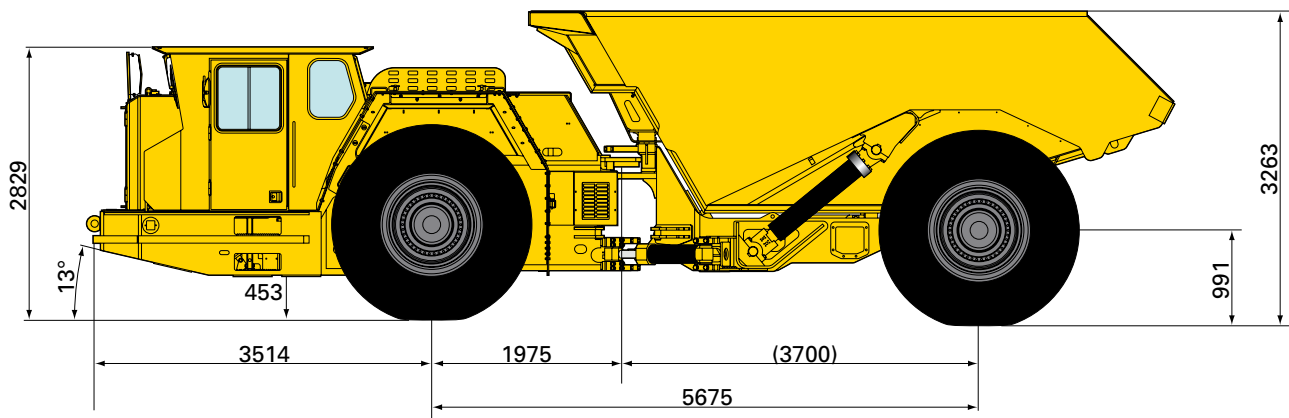

Side view

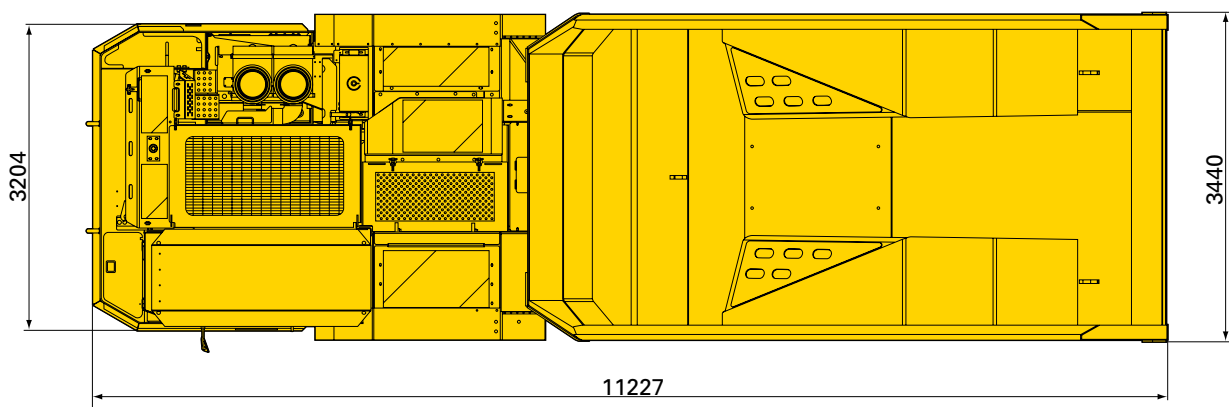

Top view

- Dimensions shown are based on standard vehicle configuration with 27 mm tyre deflection.
- All dimensions are shown in millimetres.



© Copyright 2007, Atlas Copco Rock Drills AB, Örebro, Sweden. Any unauthorized use or copying of the contents or any part thereof is prohibited. This applies in particular to trademarks, model denominations, part numbers and drawings. Illustrations and photos in this brochure may show equipment with optional extras. Specifications and equipment subjects to change without notice. Consult your Atlas Copco Customer Center for specific information.