

2008 Sandvik DS420C Bolting Rig Rebuilt



Make	Sandvik		Model	DS420		
Year	2008	Hours	1850		As at	01/07/2021
Mileage				km	As at	
Serial/VIN	108B13355-1			Engine Serial		
Details	<p>2008 Sandvik DS420C Bolting Rig Rebuilt. Showing 2 percussion hours and 1 hour on the compressor since rebuild, this bolting rig presents in exceptional condition with all items either rebuilt or new as per the scope of work available from GES. Offered for sale via online auction in "As Is" condition, running to drive on to buyers transport ex site Caboolture region, Qld. Australia.</p>					
Asking price	AUD	Under review - call for pricing				
Ex site	Australia, Queensland, Wamuran					
Service history	Showing 2 percussion hours and 1 hour on the compressor since rebuild, this bolting rig presents in exceptional condition.					

**For further details, to make an offer or book an inspection, contact
Global Equipment Solutions on Office: 08 9201 1142**

















Sandvik 2008 DS420 Cable Bolter Scope

Model:	DS420	Serial No:	108B13355-1
Year	1-May-08	Plant No:	TBA
MOB:	0402 516 700	Eng Hrs:	1850
Percussion HR :	2	Compressor HR`	1

Description	Rebuilt/New
Cabin	
Glass	New
Drivers Console	Rebuilt
Panels/ Switches	Replaced as required
Mounts/CAB	New
Door Handles	New
Pressure Gauges /Lines	New
Stainless Cab	Yes
Gui Panel	Rebuilt
Wiper Motors/ Arms	New

Electrical	
Trailing Cable	Tested
HV Power Pck	Rebuilt
High Voltage	All Tested
Din Leads	New
Front Harnesses	New
Rear module Harnesses	Replaced as required
Alternator	New
Starter Motor	New
Lights	New

Engine / Cooling system	
Cooler Pack	Rebuilt
Induction Hoses	New
Clamps	New
Cooling hoses	New
Drive Belt	New
Turbo	New
Exhaust system	New
exhaust System clamps	New
Belt Tensioner	New

PowerTrain	
Front Axel	Rebuilt
Rear Axel	Rebuilt
Transmission	1850HR
Drive Shafts	Rebuilt
Breathers	New

Hydraulics	
Hydraulic Hoses	New
SLU	Rebuilt
Lift /Swing Cylinder	Rebuilt
Jack Lef Cylinders	Rebuilt
Feed Cylinder	New
Zoom Cylinder	Rebuilt
Rail Exstension	Rebuilt
DPU Swing/ Tilt Cylinders	Rebuilt
Rod Handler Cylinders	Rebuilt/New
DCV Valves	New
Hydraulic Cooler	New

Front Module	
HL510	Rebuilt
Feed Rail	Inspected
Pins / Bushes	New
Carousel/Rodhandler	Rebuilt
Feed Beam SS strips	New
Slide Bodys/ Slide pieces	New
Feed Ropes	New
Rollover	Rebuilt
Pito Assembly	Rebuilt
Grout Hose feeder Assymbly	Rebuilt
Wire Feeder Assyembly	Rebuilt
Zoom Buttons	New
Zoom Wear plates	New
Feed cylinder Guides and pulleys	New
brake accumulators	New
Grout Hose Reel	Rebuilt
Grout Hose	New
Pressure Cleaner /Hose Reel	New
Form Oiler/Hose Reel	New
Side Platforms	Rebuilt
DPU	Rebuilt

Rear Module	
Center Hitch Pins / Bushes	New
Compressor	Rebuilt
A/C Unit	Rebuilt
Water Boost Pump	New
Fire Suppression System	New
Tyres	New (Solid Filled)
Pressure Switches	New
Water Hose Reel	Rebuilt
Water Hose	New
Cassete Swing Cylinder	Rebuilt
Cassete Reel Rollers	New
Cement Bowl	Rebuilt
Bowl Dump Cylinder	New
Cement Pump	New
Bowl Extraction Fan/ Hose	New
Hydraulic Cooler	New

Paint	
Decals	New
Paint 2K	New
Sand Blasted	complete

Commission	
2000HR Service	Completed
1000V Tested	Completed





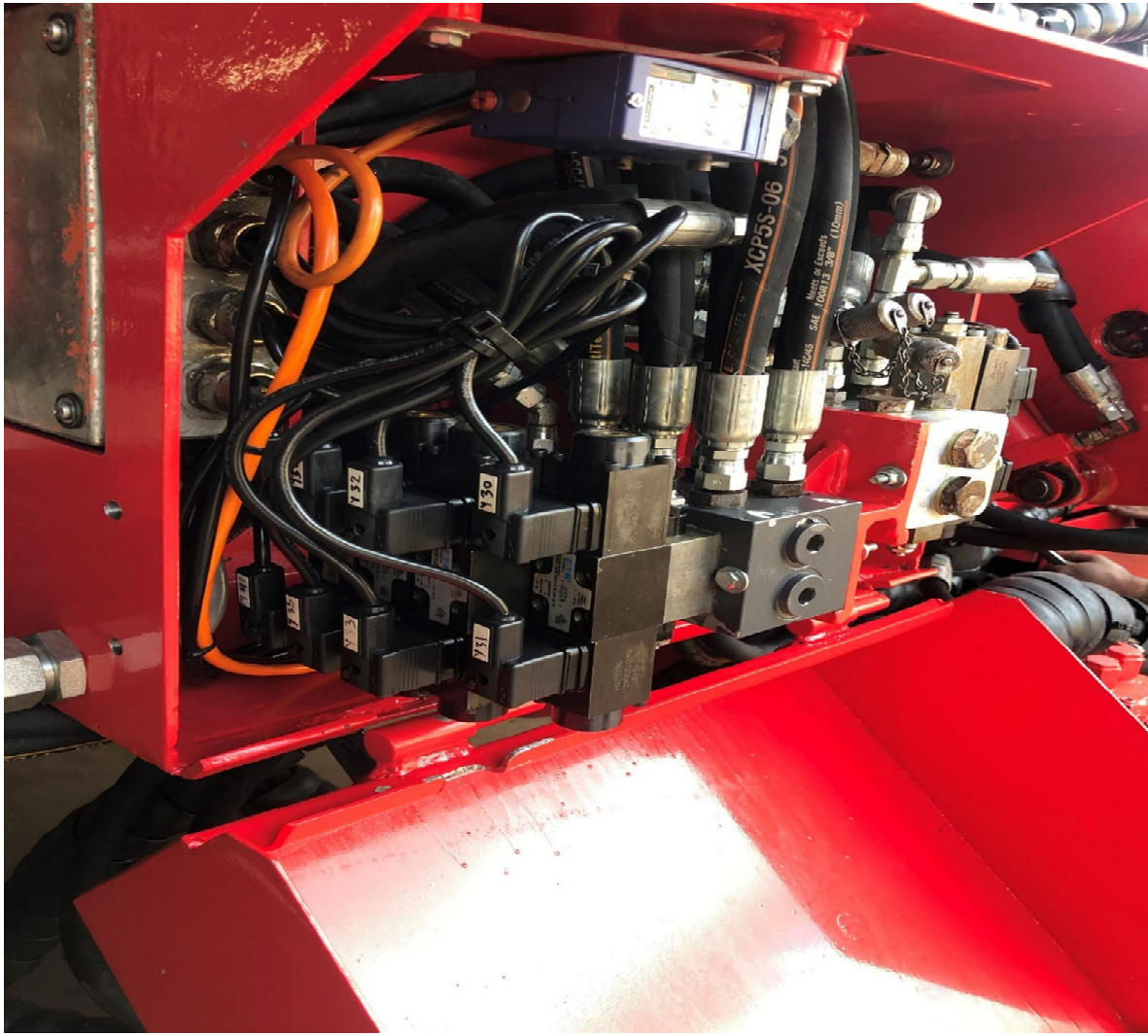

Sandvik DS420

Pioneer in cable bolting



Sandvik DS420 is a sophisticated cable bolting jumbo for rock re-inforcement in underground mines and tunnels with small and medium cross sections.

Sandvik has the longest experience in making cable bolting rigs on the market, with more than fifty units delivered around the world. This unit is a combination of proven longhole drill components and innovative bolting solutions.

The full bolting cycle can be done safely by one operator located under the canopy or in soundproof, air-conditioned cabin. The correct water/cement ratio and hole location can be easily controlled by the operator. Automatic grout hose washing, bolting head oiler and easy mixer cleaning of the machine minimize maintenance time. The onboard instrumentation with depth measurement for hole length, cement hose and steel strand ensures high quality, long-lasting end result.

Available features

- Max. cable bolt length 25 m
- Air-conditioned, soundproof cabin
- TC7 carrier with excellent serviceability

Main dimensions, Sandvik DS420

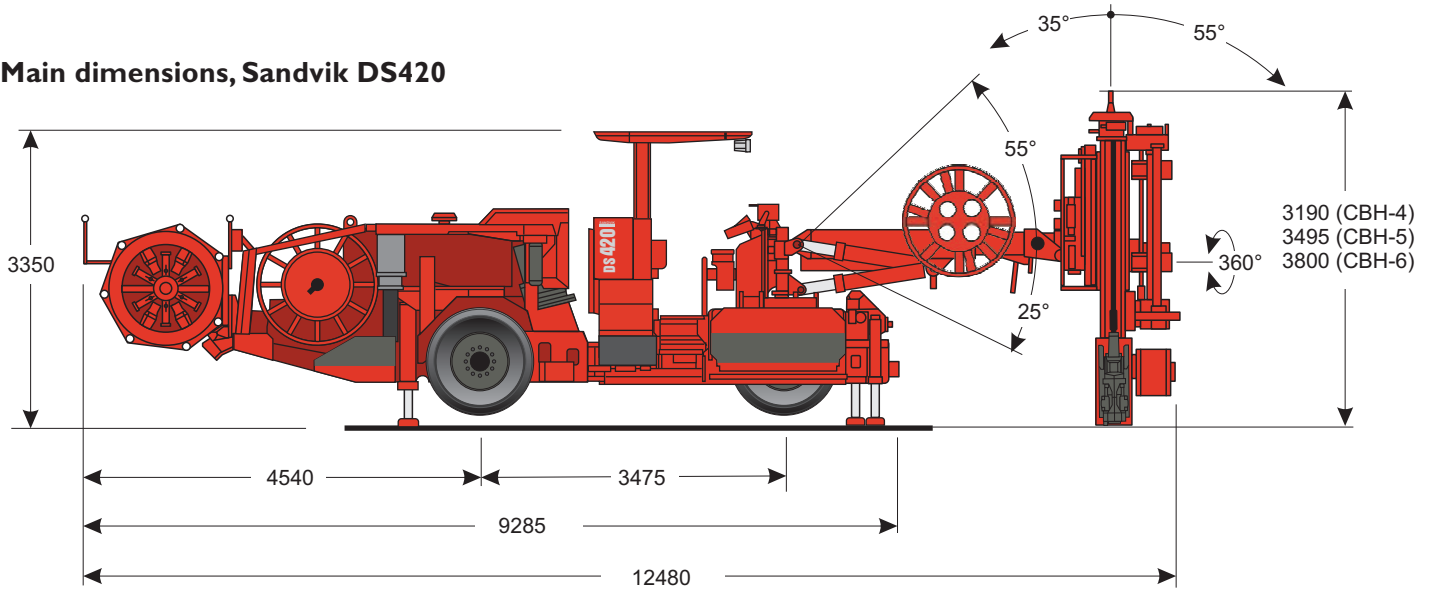

Bolting areas

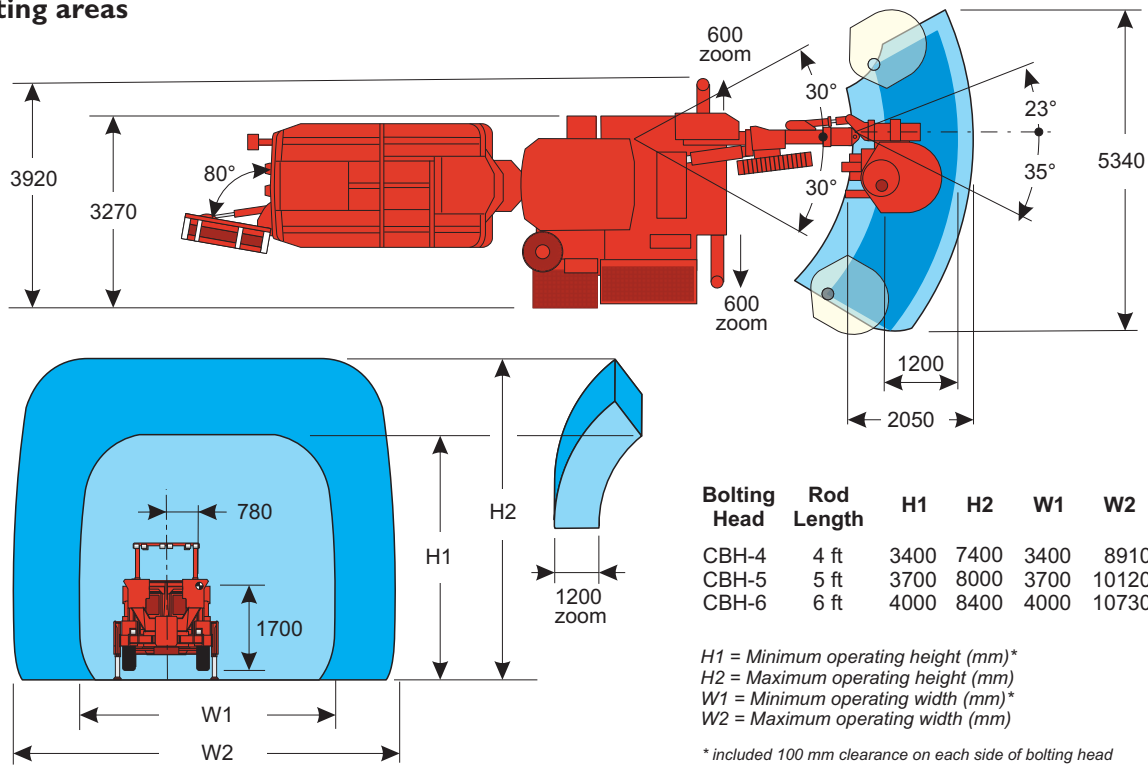

Sandvik DS420 series products

Model	Min drift size (height x width) / m (ft)	Bolt type	Bolt length / m (ft)	Working height / m (ft)	Canopy / cabin
DS420	3.4 x 3.4 (11.2 x 11.2)	Cable (Steel strand)	Up to 25 (82)	3.4 - 8.4 (11 - 28)	Canopy
DS420-C	3.4 x 3.4 (11.2 x 11.2)	Cable (Steel strand)	Up to 25 (82)	3.4 - 8.4 (11 - 28)	Cabin

