

2011 Caterpillar 299D High Flow XPS 2 Speed Skidsteer Loader



Make	Caterpillar		Model	299D		
Year	2011	Hours	2230		As at	06/03/2019
Mileage				km	As at	
Serial/VIN	CAT0299DTHCL00391			Engine Serial		
Details	<p>2011 Caterpillar 299D High Flow XPS 2 Speed Skidsteer Loader with 5 attachments as one package. 2-speed machine with high flow XPS hydraulic system and sold with Norm Engineering 4in1 bucket, Caterpillar forks, Himac rock bucket, Himac stump bucket, Custom rock/stick rake with Custom V drain tool fitted to stump bucket. Currently has less than 2,300 hours since new and set up to mine spec with flashing light. New wiring harness installed Feb 2019. Requires new windscreen wiper & wiper motor and air conditioner will need a service. Westrac inspection March 27th notes "Machine in overall good condition for age and hours" Offered for sale via online auction on an "As Is Where Is" basis driven on to buyers transport ex-site Chittering (45 minutes from Midland), Western Australia.</p>					
Asking price	AUD	Under review - call for pricing				
Ex site	Australia, Western Australia, Midland					

Service history

Westrac inspection March 27th notes "Machine in overall good condition for age and hours"
New wiring harness installed Feb 2019.
Requires new windscreen wiper & wiper motor and air conditioner will need a service.
Paint has scratches from tree removal works over the last 200 hours of operation.

**For further details, to make an offer or book an inspection, contact
Global Equipment Solutions on Office: 08 9201 1142**















Daily SSL/MTL Inspection

Form Order Report

Inspection Number:	1754783	Make:	CATERPILLAR
Equipment Family:	SKID STEER LOADER	Model:	299D
Inspector:	Robert Telfer	Serial Number:	HCL00391
Completed On:	3/27/2019 2:25:05 PM	SMU:	2227 Hours
Customer Name:	John Reilly	Customer Email:	robert.telfer@westrac.com.au
Work Order:	LT28085	Coordinates:	0 , 0 , 0

Technician

General Info / Comments

Comment - 1 : Machine in overall good condition for age and hours

From The Ground

- 1.1 Check lights
Response : Normal
No Comment Provided

- 1.2 Steps & Handrails
Response : Normal
No Comment Provided

- 1.3 Tires
Response : Normal
→ Some track wear

- 1.4 Oil Lines
Response : Normal
No Comment Provided

- 1.5 Hydraulic Oil Level
Response : Normal
No Comment Provided

- 1.6 Grease fittings
Response : Normal
No Comment Provided

- 1.7 Obvious damage to Body/Cab
Response : Monitor
→ Some paint damage, normal for age and hours of machine

- 1.8 Work Tool
Response : Normal
No Comment Provided

Engine Compartment

- 2.1 Engine Oil
Response : Normal
No Comment Provided

- 2.2 Engine Coolant
Response : Normal
No Comment Provided

- 2.3 Lines, Hoses, and Seals
Response : Normal
No Comment Provided

- 2.4 Precleaner and Air Cleaner
Response : Normal
No Comment Provided

- 2.5 Belts
Response : Normal
No Comment Provided

- 2.6 Belt Guards
Response : Normal
No Comment Provided

- 2.7 ENGINE COMPARTMENT - Engine
Response : Normal
No Comment Provided

Inside The Cab

- 3.1 Inspect condition of electric column. Ensure switches, gauges and lights are functional.
Response : Normal
No Comment Provided

3.2 Seat Belt - PM
Response : Pass
No Comment Provided

3.3 Back Up Alarm/Horn
Response : Normal
No Comment Provided

3.4 Windows and Mirrors
Response : Monitor
→ Cab door gas strut weak

3.5 ROPS
Response : Normal
No Comment Provided

3.6 Overall Cab Interior
Response : Normal
No Comment Provided



Cat[®] 299D

COMPACT TRACK LOADER

FEATURES:

The Cat[®] 299D Compact Track Loader, with its vertical lift design, delivers extended reach and lift height for quick and easy truck loading. The torsion axle suspension system provides superior traction, flotation and the ability to work in a wide range of underfoot conditions and applications. The 299D features the following:

- **Sealed and pressurized cab option** provides a cleaner and quieter operating environment.
- **Seat mounted adjustable joystick controls and available air ride seat** make the D Series the industry leader in operator comfort.
- **High performance power train** provides maximum performance and production capability through the Electronic Torque Management system, standard two speed travel and an industry exclusive electronic hand/foot throttle with decel pedal capability.
- **Electronically controlled Cat C3.8 engine** provides high horsepower and torque while meeting U.S. EPA Tier 4 Interim (EU Stage IIIB) requirements.
- **Cat "Intelligent Leveling" system (ILEV)** provides industry leading technology, integration and optional features such as dual direction self level, work tool return to dig and work tool positioner.
- **High Flow XPS hydraulic system** is available for applications that demand maximum hydraulic work tool performance.
- **Standard fully independent torsion axle suspension** combined with the optional Speed Sensitive Ride Control system improves operation on rough terrain, enabling better load retention, increased productivity and greater operator comfort.
- **Easy routine maintenance** helps reduce machine downtime for greater productivity.
- **Broad range of performance matched Cat Work Tools** make the Cat Compact Track Loader the most versatile machine on the job site.

Specifications

Engine

Engine Model	Cat [®] C3.8 (turbocharged)	
Gross Power SAE J1995	73 kW	98 hp
Net Power SAE 1349	71 kW	95 hp
Displacement	3.8 L	232 in ³
Stroke	120 mm	4.7 in
Bore	100 mm	3.9 in

Weights*

Operating Weight	4943 kg	10,898 lb
------------------	---------	-----------

Power Train

Travel Speed (Forward or Reverse):		
One Speed	8.1 km/h	5.0 mph
Two Speed	13.6 km/h	8.5 mph

Hydraulic System

Hydraulic Flow – Standard:		
Loader Hydraulic Pressure	23 000 kPa	3,335 psi
Loader Hydraulic Flow	86.4 L/min	23 gal/min
Hydraulic Power (calculated)	33 kW	44 hp
Hydraulic Flow – High Flow XPS:		
Max. Loader Hydraulic Pressure	28 000 kPa	4,061 psi
Max. Loader Hydraulic Flow	120 L/min	32 gal/min
Hydraulic Power (calculated)	57 kW	76 hp

*Operating Weight, Operating Specifications and Dimensions all based on 75 kg (165 lb) operator, all fluids, two speed, counterweights, 1981 mm (78 in) Dirt Bucket, 450 mm (17.7 in) wide tracks, dual flange front idler/single flange rear idler, OROPS with mechanical suspension seat and manual quick coupler (unless otherwise noted).

Operating Specifications

Rated Operating Capacity:			
35% Tipping Load	1350 kg	2,975 lb	
50% Tipping Load	1928 kg	4,250 lb	
Rated Operating Capacity with Optional Counterweight			
Tipping Load	2041 kg	4,500 lb	
Breakout Force, Tilt Cylinder	3855 kg	8,500 lb	
Breakout Force, Tilt Cylinder	3348 kg	7,381 lb	
Breakout Force, Lift Cylinder	2767 kg	6,100 lb	
Ground Contact Area	1.59 m ²	2,463 in ²	
Ground Pressure	30.5 kPa	4.4 psi	

Cab

ROPS	SAE J1040 MAY94, ISO 3471:1994
FOPS	SAE J1043 SEPT87, ISO 3449:1992 Level I
FOPS Level II	SAE J231 JAN81, ISO 3449:1992 Level II

Service Refill Capacities

Cooling System	14 L	3.7 gal
Engine Crankcase	10 L	2.6 gal
Fuel Tank	117 L	30.8 gal
Hydraulic System	61 L	16.0 gal
Hydraulic Tank	39 L	10.3 gal



299D Compact Track Loader

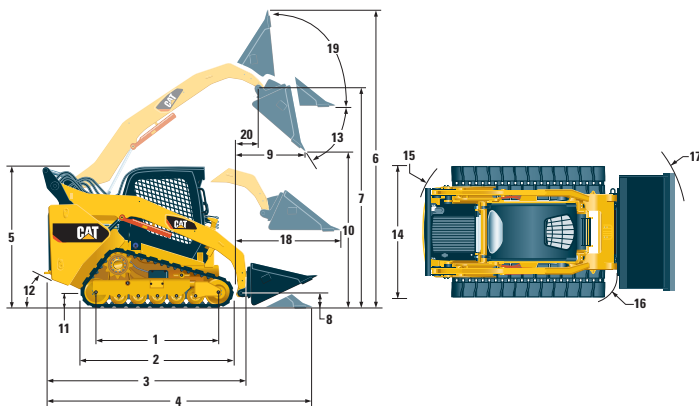

Dimensions

1 Length of Track on Ground	1767 mm	69.6 in
2 Overall Length of Track	2270 mm	89.4 in
3 Length w/o Bucket	3138 mm	123.5 in
4 Length w/Bucket on Ground	3850 mm	151.6 in
5 Height to Top of Cab	2104 mm	82.8 in
6 Max. Overall Height	4048 mm	159.4 in
7 Bucket Pin Height at Max. Lift	3217 mm	126.6 in
8 Bucket Pin Height at Carry Position	195 mm	7.7 in
9 Reach at Max. Lift and Dump	787 mm	31.0 in
10 Clearance at Max. Lift and Dump	2418 mm	95.2 in
11 Ground Clearance	231 mm	9.1 in
12 Departure Angle	39°	
13 Maximum Dump Angle	52°	
14 Vehicle Width (450 mm/17.7 in tracks)	1981 mm	78.0 in
15 Turning Radius from Center – Machine Rear	1849 mm	72.8 in
16 Turning Radius from Center – Coupler	1535 mm	60.4 in
17 Turning Radius from Center – Bucket	2347 mm	92.4 in
18 Max. Reach w/Arms Parallel to Ground	1288 mm	50.7 in
19 Rack Back Angle at Max. Height	83°	
20 Bucket Pin Reach at Max. Lift	410 mm	16.1 in

MANDATORY EQUIPMENT

- Hydraulics, Standard or High Flow XPS
- Quick Coupler, Mechanical or Electric
- Seat Belt, 50 mm (2 in) or 75 mm (3 in)

COMFORT PACKAGE (must select one of the following)

- Open ROPS (C1): *Radio Ready, Suspension Seat, (No Heater or Door)*
- Enclosed ROPS with Heat (C2): *Cup Holder, Radio Ready, Seat (choice of Suspension or Air Ride), Heater and Defroster, Side Windows, Door (either Glass or Polycarbonate)*
- Enclosed ROPS with A/C (C3): *C2 + Air Conditioner*

HYDRAULIC PERFORMANCE PACKAGE (must select one of the following)

- (H1) *Standard Flow*
- (H2) *Standard Flow, Dual Direction Electronic Self Level (raise and lower), Electronic Snubbing (Lift)*
- (H3) *High Flow XPS, Dual Direction Electronic Self Level (raise and lower), Electronic Snubbing (Lift)*

UNDERCARRIAGE

- Steel Imbed Rubber Track – 400 mm (15.7 in) with Triple Flange Idlers (front and rear), Suspension – 4 Independent Torsion Axles
- Steel Imbed Rubber Track – 450 mm (17.7 in) with Dual Flange Front Idler and Single Flange Rear Idler, Suspension – 4 Independent Torsion Axles

STANDARD EQUIPMENT

ELECTRICAL

- 12 volt Electrical System
- 100 ampere Alternator
- Automatic Glow Plug Activation
- Ignition Key Start/Stop Switch
- Lights: *Gauge Backlighting, Two Rear Tail Lights, Two Rear Halogen Working Lights, Two Adjustable Front Halogen Lights, Dome Light*
- Backup Alarm
- Heavy Duty Battery, 1,000 CCA

OPERATOR ENVIRONMENT

- Gauges: *Fuel Level, Hour Meter*
- Operator Warning System Indicators: *Air Filter Restriction, Alternator Output, Armrest Raised/Operator Out of Seat, Engine Coolant Temperature, Engine Oil Pressure, Glow Plug Activation, Hydraulic Filter Restriction, Hydraulic Oil Temperature, Park Brake Engaged, Regeneration – Engine Emissions*
- Vinyl Seat, Mechanical Suspension
- Fold in Ergonomic Contoured Armrest
- Control Interlock System, when operator leaves seat or armrest raised: *Hydraulic System Disables, Hydrostatic Transmission Disables, Parking Brake Engages*
- ROPS Cab, Open, Tilt Up
- FOPS, Level I
- Top and Rear Windows
- Headliner, Deluxe
- Floor Mat
- Interior Rearview Mirror
- 12 volt Electric Socket
- Horn
- Hand (Dial) and Foot Throttle, Electronic with Decel Feature

POWER TRAIN

- Cat® C3.8, Turbo, Tier 4 Interim (Stage IIIB) Certified Engine
- Air Cleaner, Dual Element, Radial Seal
- S-O-SSM Sampling Valve, Hydraulic Oil
- Filters, Cartridge-type, Hydraulic
- Filters, Cartridge-type, Fuel and Water Separator
- Radiator/Hydraulic Oil Cooler (side-by-side)
- Spring Applied, Hydraulically Released, Wet Multi Disc Parking Brakes
- Hydrostatic Transmission, Two Speed Travel
- Suspension – Independent Torsion Axles (4)

OTHER

- Engine Enclosure, Lockable
- Extended Life Antifreeze, –37° C (–34° F)
- Machine Tie Down Points (4)
- Support, Lift Arm
- Hydraulic Oil Level Sight Gauge
- Radiator Coolant Level Sight Gauge
- Radiator, Expansion Bottle
- Cat ToughGuard™ Hose
- Auxiliary, Hydraulics, Continuous Flow
- Heavy Duty, Flat Faced Quick Disconnects with Integrated Pressure Release
- Split D-Ring to Route Work Tool Hoses Along Side of Left Lift Arm
- Electrical Outlet, Beacon
- Belly Pan Cleanout
- Variable Speed Demand Fan

OPTIONAL ATTACHMENTS

- Counterweight
- Beacon, Rotating
- Engine Block Heater – 120V
- Oil, Hydraulic, Cold Operation
- Heavy Duty Battery, 1,000 CCA
- Paint, Custom
- AM/FM/Weather Band Receiver with CD Player and Auxiliary Input Jack
- Ride Control
- Advanced Machine Information and Control System (AMICS)
- Work Tool Return to Dig and Work Tool Positioner

For more complete information on Cat products, dealer services, and industry solutions, visit us on the web at www.cat.com

© 2012 Caterpillar
All Rights Reserved
Printed in U.S.A.

Materials and specifications are subject to change without notice. Featured machines in photos may include additional equipment. See your Cat dealer for available options.

CAT, CATERPILLAR, SAFETY.CAT.COM, their respective logos, "Caterpillar Yellow" and the "Power Edge" trade dress, as well as corporate and product identity used herein, are trademarks of Caterpillar and may not be used without permission.

AEHQ6564-01 (05-12)
Replaces AEHQ6564

