

Volvo L90F Tool Carrier IT016



Make	Volvo		Model	L90F		
Year		Hours	1598		As at	01/12/2019
Mileage				km	As at	
Serial/VIN	VCE0L90FE72876			Engine Serial		
Details	Volvo L90F Wheel Loader / Tool Carrier Asset no IT016. This IT is sold as machine only with no tools included.. Offered for sale via online auction ex Site Nifty Copper Mine via Telfer Western Australia, running to drive on to buyers transport. See Google Maps link: https://goo.gl/maps/Xvaa3uBAFso9MP7A8					
Asking price	AUD	Under review - call for pricing				
Ex site	Australia, Western Australia, Telfer					

Service history	This IT is sold as machine only with no tools included.
------------------------	---------------------------------------------------------

**For further details, to make an offer or book an inspection, contact
Global Equipment Solutions on Office: 08 9201 1142**













4.1.7 IT0016 VOLVO L90F

- New 12th July 2019

Asset Number	Make	Model	Current SMU reading (hrs)	All-time SMU
IT016	Volvo	L90F	1598	1598

4.1.8 IT0016 SUMMARY

Reliable UG IT - New

SPECIFICATIONS

Tires: 20.5 R25 L2

	Standard boom			Long boom		
	L60F	L70F	L90F	L60F**	L70F	L90F
B	5990 mm 19'8"	6050 mm 19'10"	6120 mm 20'1"	6500 mm 21'4"	6530 mm 21'5"	6550 mm 21'6"
C	3000 mm 9'10"	3000 mm 9'10"	3000 mm 9'10"	-	-	-
D	460 mm 1'6"	460 mm 1'6"	460 mm 1'6"	-	-	-
F	3220 mm 10'7"	3280 mm 10'9"	3280 mm 10'9"	-	-	-
G	2130 mm 7'0"	2130 mm 7'0"	2130 mm 7'0"	-	-	-
J	3580 mm 11'9"	3580 mm 11'9"	3650 mm 12'0"	4100 mm 13'5"	4050 mm 13'3"	4080 mm 13'5"
K	3870 mm 12'9"	3870 mm 12'8"	3960 mm 13'0"	4390 mm 14'5"	4340 mm 14'3"	4390 mm 14'5"
O	56°	56°	57°	57°	52°	57°
P _{max}	45°	46°	44°	44°	45°	-
R	42°	42°	44°	43°	44°	47°
R ₁ *	47°	48°	49°	50°	52°	53°
S	79°	68°	67°	-	72°	65°
T	93 mm 0'3.7"	110 mm 0'4.3"	110 mm 0'4.4"	130 mm 0'5.1"	118 mm 0'4.6"	116 mm 0'4.6"
U	450 mm 1'6"	450 mm 1'6"	490 mm 1'7"	590 mm 1'11"	560 mm 1'10"	590 mm 1'11"
X	1900 mm 6'3"	1930 mm 6'3"	1960 mm 6'5"	-	-	-
Y	2440 mm 8'0"	2470 mm 8'1"	2490 mm 8'2"	-	-	-
Z	3210 mm 10'6"	3200 mm 10'6"	3300 mm 10'10"	3600 mm 11'10"	3500 mm 11'6"	3660 mm 12'0"
a ₂	5340 mm 17'6"	5350 mm 17'7"	5370 mm 17'7"	-	-	-
a ₃	2900 mm 9'6"	2890 mm 9'6"	2880 mm 9'5"	-	-	-
a ₄	±40°	±40°	±40°	-	-	-

* Carry position SAE **) 17.5 R25 tires not allowed.

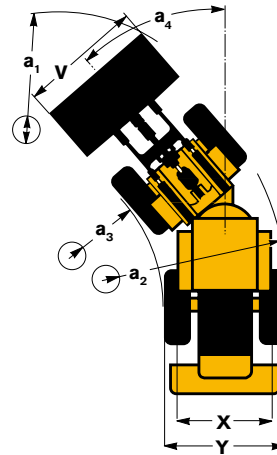

Where applicable, specifications and dimensions are according to ISO 7131, SAE J732, ISO 7546, SAE J742, ISO 14397, SAE J818.

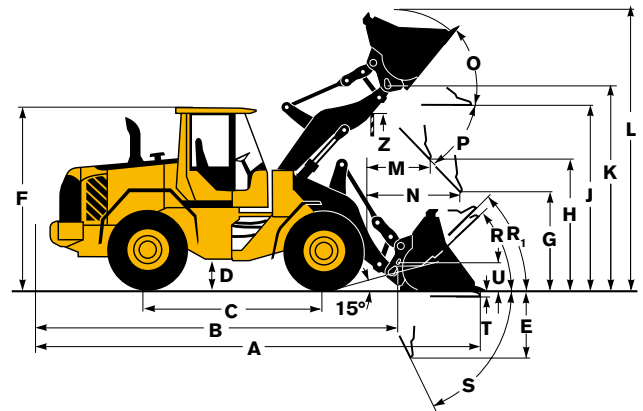

Tires: 20.5 R25 L2

	L60F	L70F	L90F
A	800 mm 2'7"	830 mm 2'9"	960 mm 3'2"
B	1560 mm 5'1"	1600 mm 5'3"	1700 mm 5'7"
C	-40 mm -0'1.6"	-46 mm -0'1.8"	-8 mm -0'0.3"
D	1830 mm 6'0"	1850 mm 6'1"	1790 mm 5'10"
E	3710 mm 12'2"	3730 mm 12'3"	3770 mm 12'4"
F	690 mm 2'3"	760 mm 2'6"	740 mm 2'5"
Operating load* at load rated distance	4350 kg 600 mm 9,590 lb 1'12"	4900 kg 600 mm 10,800 lb 1'12"	5700 kg 600 mm 12,570 lb 2'0"
Operating weight	11 450 kg 25,240 lb	12 950 kg 28,550 lb	14 500 kg 31,970 lb

Fork tine sales code L60F and L70F (R/L): WLA80042/80043

Fork tine sales code L90F (R/L): WLA80344/80345

Length: 1200 mm (3'11")

Fork frame order no.: 80041

* acc. std EN 474-3, firm and level ground

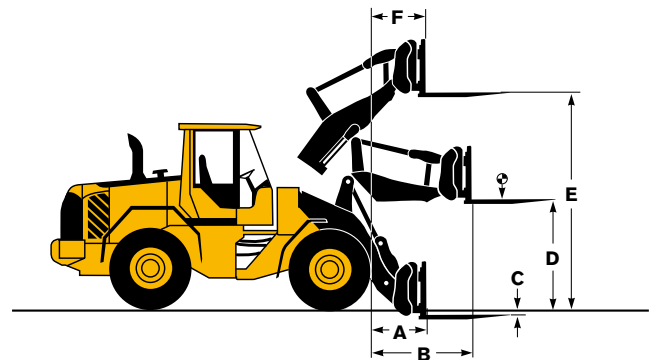

Tires: 20.5 R25 L2

	L60F	L70F	L90F
A*	1800 kg 3,970 lb	2150 kg 4,740 lb	2760 kg 6,080 lb
B*	1400 kg 3,090 lb	1710 kg 3,770 lb	2130 kg 4,700 lb
C*	1150 kg 2,540 lb	1400 kg 3,090 lb	1740 kg 3,840 lb
D	2580 mm 8'6"	2720 mm 8'11"	2640 mm 8'8"
E	1990 mm 6'6"	2110 mm 6'11"	2040 mm 6'8"
F	1450 mm 4'9"	1550 mm 5'1"	1440 mm 4'9"
G	3270 mm 10'9"	3320 mm 10'11"	3280 mm 10'9"
H	4300 mm 14'1"	4360 mm 14'4"	4410 mm 14'6"
I	5440 mm 17'10"	5490 mm 18'0"	5550 mm 18'3"
J	910 mm 3'0"	1270 mm 4'2"	1370 mm 4'6"
K	1240 mm 4'1"	1750 mm 5'9"	1920 mm 6'4"
L	1590 mm 5'3"	2270 mm 7'5"	2470 mm 8'1"
M	2250 mm 7'5"	2180 mm 7'2"	2040 mm 6'8"
N	3230 mm 10'7"	3100 mm 10'2"	3030 mm 9'11"
O	4310 mm 14'2"	4110 mm 13'5"	4020 mm 13'2"
P	1520 mm 5'0"	1520 mm 5'0"	1530 mm 5'0"
Q	5300 mm 17'5"	5290 mm 17'4"	5330 mm 17'6"
R	6180 mm 20'3"	6170 mm 20'3"	6290 mm 20'8"
S	7150 mm 23'5"	7120 mm 23'4"	7250 mm 23'9"

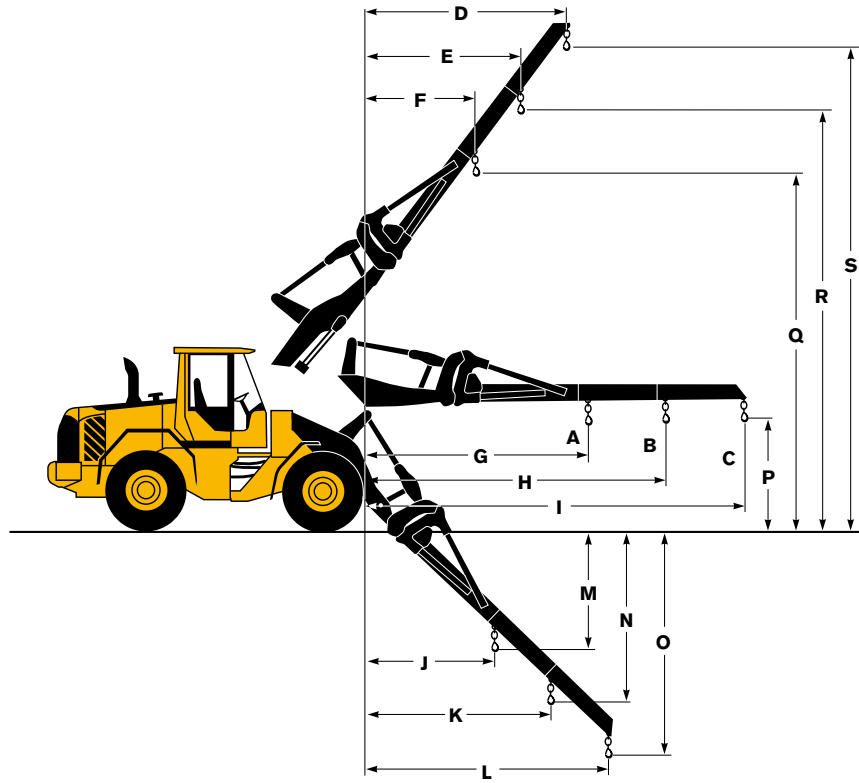

L60F
Sales code: WLA92007
Operating weight:
11 370 kg (25,070 lb)

L70F
Sales code: WLA92007
Operating weight:
12 860 kg (28,350 lb)

L90F
Sales code: WLA92008
Operating weight:
14 440 kg (31,830 lb)

* Carry position SAE

Tires: 20.5 R25 L2

	L60F	L70F	L90F
A	1,3 m ² 14.0 ft²	1,5 m ² 16.1 ft²	2,4 m ² 25.8 ft²
B	3420 mm 11'3"	3380 mm 11'1"	3420 mm 11'3"
C	1480 mm 4'10"	1600 mm 5'3"	1830 mm 6'0"
D	2940 mm 9'8"	2870 mm 9'5"	2790 mm 9'2"
E	1170 mm 3'10"	1270 mm 4'2"	1440 mm 4'9"
F	1540 mm 5'1"	1500 mm 4'11"	1440 mm 4'9"
G	2350 mm 7'9"	2440 mm 8'0"	2770 mm 9'1"
H	4340 mm 14'3"	4380 mm 14'4"	4540 mm 14'11"
I	5890 mm 19'4"	6030 mm 19'9"	6580 mm 21'7"
J	2000 mm 6'7"	2140 mm 7'0"	2790 mm 9'2"
K	2080 mm 6'10"	2370 mm 7'9"	2990 mm 9'10"
L	1700 mm 5'7"	1800 mm 5'11"	2160 mm 7'1"
M	7830 mm 25'8"	7960 mm 26'1"	8420 mm 27'8"

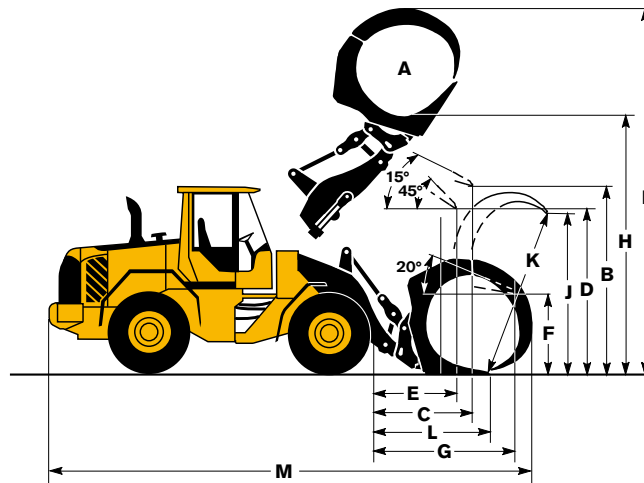

L60F
Sales code: WLA82194
Operating weight
(incl. logging cw 120 kg (260 lb)):
12 210 kg (26,920 lb)
Operating load: 3450 kg (7,600 lb)

L70F
Sales code: WLA80153
Operating weight
(incl. logging cw 250 kg (550 lb)):
13 590 kg (29,960 lb)
Operating load: 3390 kg (7,470 lb)

L90F
Sales code: WLA80832
Operating weight
(incl. logging cw 500 kg (1,100 lb)):
15 850 kg (34,940 lb)
Operating load: 4600 kg (10,140 lb)

L90F

Tires 20.5 R25 L2	GENERAL PURPOSE										LIGHT MATERIAL		LONG BOOM
	Bolt-on edges	Teeth	Bolt-on edges	Bolt-on edges	Bolt-on edges	Bolt-on edges	Bolt-on edges	Bolt-on edges	Bolt-on edges	Bolt-on edges	Bolt-on edges	Bolt-on edges	
Volume, heaped ISO/SAE	m ³ yd ³	2.3 3.0	2.5 3.3	2.5 3.3	2.5 3.3	2.6 3.4	2.7 3.5	2.7 3.5	2.7 3.5	4.1 5.4	7.0 9.2	-	
Volume at 110% fill factor	m ³ yd ³	2.5 3.3	2.8 3.6	2.8 3.6	2.8 3.6	2.9 3.7	3.0 3.9	3.0 3.9	3.0 3.9	4.5 5.9	7.7 10.1	-	
Static tipping load, straight	kg lb	10 700 23,600	10 740 23,690	11 210 24,720	10 520 23,190	10 550 23,260	10 430 23,000	11 180 24,650	10 130 22,340	9840 21,690	9840 21,690	-1650 -3,640	
at 35° turn	kg lb	9470 20,870	9500 20,950	9 940 21,920	9300 20,500	9320 20,550	9200 20,290	9910 21,860	8920 19,670	8610 18,980	8610 18,980	-1500 -3,310	
at full turn	kg lb	9100 20,070	9140 20,150	9570 21,100	8940 19,710	8960 19,750	8840 19,490	9540 21,040	8560 18,880	8240 18,180	8240 18,180	-1460 -3,220	
Breakout force	kN lbf	113.1 25,420	112.4 25,260	118.5 26,650	108.5 24,400	106.5 23,940	104.5 23,500	113.7 25,560	84.4 18,970	73.0 16,400	73.0 16,400	+2.0 +450	
A	mm ft in	7550 24'9"	7810 25'8"	7510 24'7"	7610 25'0"	7640 25'1"	7670 25'2"	7560 24'10"	8000 26'3"	8300 27'3"	8300 27'3"	+410 +1'4"	
E	mm ft in	1200 3'11"	1430 4'8"	1160 3'9"	1250 4'1"	1280 4'2"	1300 4'3"	1200 3'11"	1600 5'3"	1860 6'1"	1860 6'1"	-6.0 -0'0"	
H*)	mm ft in	2820 9'3"	2650 8'8"	2850 9'4"	2780 9'1"	2750 9'0"	2740 9'0"	2820 9'3"	2530 8'4"	2320 7'7"	2320 7'7"	+420 +1'5"	
L	mm ft in	5380 17'8"	5460 17'11"	5370 17'7"	5430 17'10"	5460 17'11"	5490 18'0"	5430 17'10"	5560 18'3"	5760 18'11"	5760 18'11"	+420 +1'5"	
M*)	mm ft in	1130 3'8"	1310 4'4"	1090 3'7"	1170 3'10"	1180 3'10"	1210 3'11"	1130 3'8"	1470 4'10"	1670 5'6"	1670 5'6"	-50 -0'2"	
N*)	mm ft in	1700 5'7"	1770 5'10"	1680 5'6"	1720 5'8"	1720 5'8"	1730 5'8"	1690 5'7"	1740 5'8"	1730 5'8"	1730 5'8"	+360 +1'2"	
V	mm in	2650 104"	2650 104"	2650 104"	2650 104"	2650 104"	2750 108"	2750 108"	2750 108"	3000 118"	3000 118"	-	
a, clearance circle	mm ft in	11 860 38'11"	12 000 39'4"	11 840 38'10"	11 890 39'0"	11 900 39'1"	12 010 39'5"	11 950 39'3"	12 200 40'0"	12 600 41'4"	12 600 41'4"	-	
Operating weight	kg lb	15 170 33,450	15 170 33,450	14 980 33,040	15 220 33,550	15 250 33,630	15 340 33,830	14 970 33,010	15 460 34,090	15 890 35,040	15 890 35,040	+250 +550	

*) Measured to the tip of the bucket teeth or bolt-on edge. Dump height to bucket edge. Measured at 45° dump angle.

Note: This only applies to genuine Volvo attachments.

Bucket Selection Chart

The chosen bucket is determined by the density of the material and the expected bucket fill factor. The actual bucket volume is often larger than the rated capacity, due to the features of the TP Linkage, including an open bucket design, good rollback angles in all positions and good bucket filling performance. The example represents a standard boom configuration. Example: Sand and gravel. Fill factor ~ 105%. Density 1.65 t/m³ (2,780 lb/yd³). Result: The 2.7 m³ (3.5 yd³) bucket carries 2.8 m³ (3.7 yd³). For optimal stability always consult the bucket selection chart.

Material	Bucket fill, %		Material density, t/m ³ / lb/yd ³		ISO/SAE bucket volume, m ³ / yd ³		Actual volume, m ³ / yd ³	
			~	~	2.5	3.3	~	~
Earth/Clay	~ 110		~ 1.80	~ 3,030	2.5	3.3	~ 2.7	~ 3.5
			~ 1.70	~ 2,870	2.6	3.4	~ 2.9	~ 3.8
Sand/Gravel	~ 105		~ 1.65	~ 2,780	2.7	3.5	~ 3.0	~ 3.9
			~ 1.80	~ 3,030	2.5	3.3	~ 2.6	~ 3.4
Aggregate	~ 100		~ 1.70	~ 2,870	2.6	3.4	~ 2.7	~ 3.5
			~ 1.65	~ 2,780	2.7	3.5	~ 2.8	~ 3.7
Rock	≤ 100		~ 1.80	~ 3,030	2.5	3.3	~ 2.5	~ 3.3
			~ 1.70	~ 2,870	2.6	3.4	~ 2.6	~ 3.4
			~ 1.65	~ 2,780	2.7	3.5	~ 2.7	~ 3.5

The size of rock buckets is optimized for optimal penetration and filling capability rather than the density of the material.

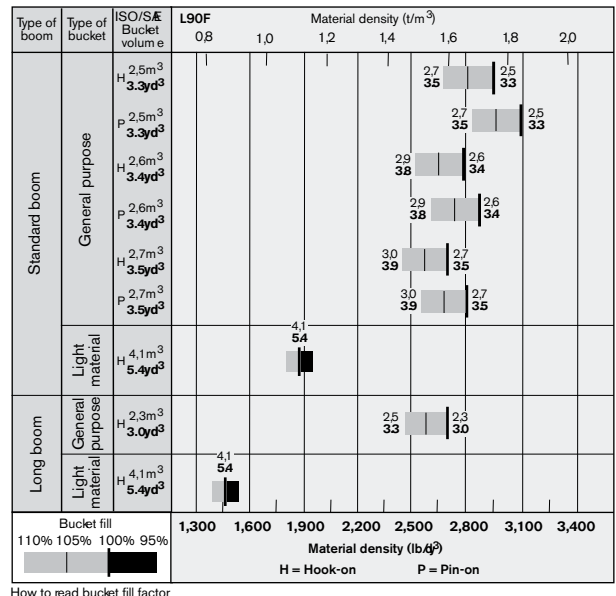

Supplemental Operating Data

Tires 20.5 R25 L2	Standard boom		Long boom	
	650/65 R25		650/65 R25	
Width over tires	mm in	+200 +8"	+200 +8"	+200 +8"
Ground clearance	mm in	0 0"	0 0"	0 0"
Tipping load, full turn	kg lb	+400 +880	+400 +880	+360 +790
Operating weight	kg lb	+600 +1,320	+600 +1,320	+600 +1,320