

2010 Caterpillar 740 Articulated Dump Truck DT012



Make	Caterpillar		Model	740		
Year	2010	Hours	9511		As at	01/12/2019
Mileage				km	As at	
Serial/VIN	CAT00740VB1P06406			Engine Serial		
Details	2010 Caterpillar 740 Articulated Truck - Dump Asset no DT012, DT006. Offered for sale via online auction ex Site Nifty Copper Mine via Telfer Western Australia, running to drive on to buyers transport. See Google Maps link: https://goo.gl/maps/Xvaa3uBAFso9MP7A8					
Asking price	AUD	Under review - call for pricing				
Ex site	Australia, Western Australia, Telfer					

Service history	
------------------------	--

**For further details, to make an offer or book an inspection, contact
Global Equipment Solutions on Office: 08 9201 1142**













6.1.13 DT012 SURFACE DUMPTRUCK CATERPILLAR 740

- Surface dump truck
- Rebuilt park brake November 2019

Asset Number	Model	Serial Number	Current SMU reading (hrs)	All-time SMU
DT012	740	B1P06406	9511	9511

6.1.14 DT012 SUMMARY

Surface truck utilisation, Run.

740 Articulated Truck

Turning Circle

Dimensions are for machines equipped with 29.5R25 tires.

Turning dimensions

Steer angle — left/right	45°
SAE turning radius	8138 mm 320.4 in
Clearance radius	8595 mm 338.4 in
Inside radius	4101 mm 161.5 in
Aisle width	5694 mm 224.2 in

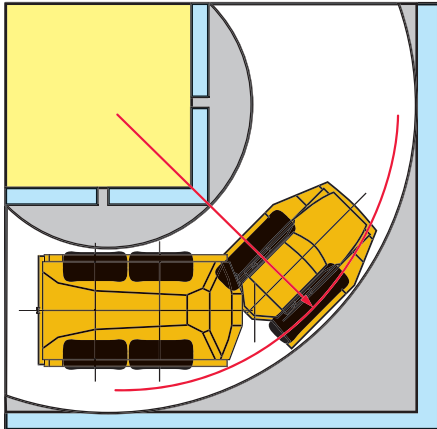

Dimensions

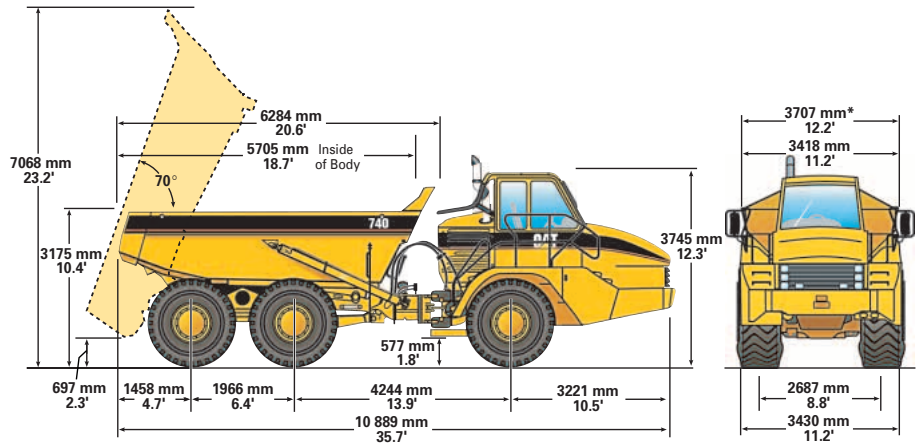

* If equipped with a scissor tailgate.

Optimal Loader/Truck Pass Matching

Hydraulic Excavators	385B L ME	365B II L ME	345B II L ME
Loader Capacity (Tonnes) – 50 min hr	954-1193	750-1100	665-805
Loader Capacity (Tons) – 50 min hr	1049-1314	825-1210	735-885
Passes	3-4	5	6

Wheel Loaders	988G	980G	972G	966G
Loader Capacity (Tonnes) – 50 min hr	565-790	590-650	490-565	400-535
Loader Capacity (Tons) – 50 min hr	625-870	650-717	540-625	440-590
Passes	3-4	4	5	5-6

An optimum system match gives you a major productivity advantage. The 740 is an excellent match for the Cat 345B II L, 365B II L, and 385B L Mass Excavators; and 972G, 980G and 988G Wheel Loaders. This results in increased production and lower system costs per unit of volume moved.

740 Articulated Truck

Gradeability/Speed/Rimpull

To determine performance, read from Gross Weight down to % Total Resistance. Total Resistance equals actual % grade plus 1% for each 10 kg/metric ton (20 lb/ton) of Rolling Resistance. From this point, read horizontally to the curve with the highest attainable speed range. Then, go down to Maximum Speed. Usable Rimpull depends on traction available.

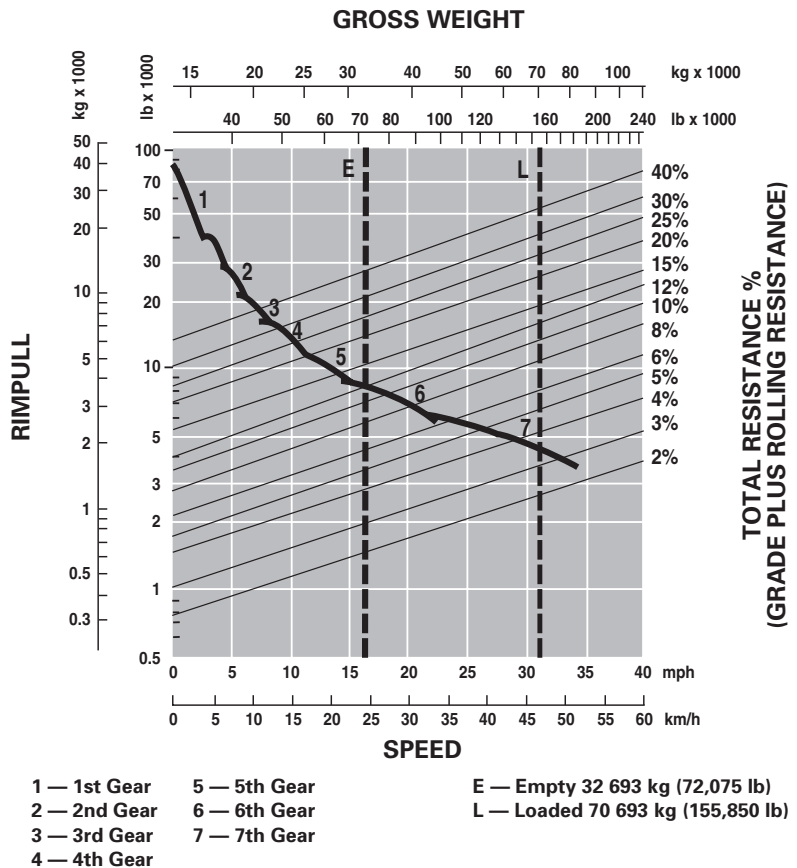

Retarding Performance

To determine performance, read from Gross Weight down to % Effective Grade. Effective Grade equals actual % favorable grade plus 1% for each 10 kg/metric ton (20 lb/ton) of Rolling Resistance. From this point, read horizontally to the curve with the highest attainable speed range. Then, go down to Maximum Speed. Retarding effect on these curves represents full application of the retarder.

