

2011 Atlas Copco MT6020 DT012,_UT12



Make	Atlas Copco		Model	MT6020		
Year	2011	Hours	22430		As at	01/04/2021
Mileage				km	As at	
Serial/VIN	AVO11X216-124			Engine Serial		
Details	Un Reserved 2011 Atlas Copco MT6020 Asset DT012,_UT12. Offered for sale via Online auction in "As Is" condition, running to drive on to buyers transport. Located at Savannah Nickel Mine, via Kununurra Western Australia.					
Asking price	AUD	Under review - call for pricing				
Ex site	Australia, Western Australia, Kununurra					

Service history	
------------------------	--

**For further details, to make an offer or book an inspection, contact
Global Equipment Solutions on Office: 08 9201 1142**











Work Order	Description	Start Date	Status	Cost Centre	Key/Section	PM Task	Branch
117948	Carry out fire suppression service	10-Sep-18	F	4202131	AFFF	2227	CAP
117971	3 Monthly work order for daily services & minor repairs	1-Oct-18	F	4202131	WHOLE	2108	CAP
118229	Replace damaged radiator, fan and condenser	29-Oct-18	F	4202131	WHOLE		CAP
118231	Replace failed bonnet gas struts	30-Oct-18	F	4202131	WHOLE		CAP
118506	DT, Carry out 250hr service as per attached sheet	7-Dec-18	F	4202131	250HR	2244	CAP
123295	DT, Carry out 2000hr service as per attached sheet	22-Dec-18	F	4202131	2000HR	2247	CAP
123275	3 Monthly work order for daily services & minor repairs	1-Jan-19	F	4202131	WHOLE	2108	CAP
123243	Replace corroded air filter housing	5-Jan-19	F	4202131	ENGINE		CAP
123842	DT, Carry out 250hr service as per attached sheet	19-Jan-19	F	4202131	250HR	2244	CAP
146863	DT, Carry out 250hr service as per attached sheet	26-Jan-19	F	4202131	250HR	2244	UG
125793	DT, Carry out 500hr service as per attached service sheet	3-Feb-19	F	4202131	500HR	2245	CAP
126890	check tension of steering cylinder cap bolts	8-Feb-19	F	4202131	FRAME		UG
126916	TEST PARK BRAKE SYSTEM AS PER MANUFACTURES GUIDLINES	9-Feb-19	F	4202131	BRAKE		UG
126954	Diagnose and repair highspeed shaft failure	9-Feb-19	F	4202131	DRIVE		CAP
127746	DT, Carry out 250hr service as per attached sheet	26-Feb-19	F	4202131	250HR	2244	UG
128906	INSPECT THE FUEL TANK BREATHER IS NOT POINTING TOWARD THE	2-Mar-19	F	4202131	ENGINE		UG
129165	REPLACE POS 1 AND 2 TYRES	3-Mar-19	F	4202131	TYRE		UG
129205	Replace retarder pedal due to oil leak	6-Mar-19	F	4202131	CABIN		UG
129207	Carry out fire suppression service	10-Mar-19	F	4202131	AFFF	2227	UG
129222	DT, Carry out 1000hr service as per attached sheet	11-Mar-19	F	4202131	1000HR	2246	UG
129558	Replace Transmission Temp Sender	15-Mar-19	F	4202131	TRANS		UG
129818	Replace cab seat with correct seat	19-Mar-19	F	4202131	CABIN		UG
129819	Replace leaking steering neutralizer	19-Mar-19	F	4202131	STEER		UG
130070	Tub Repairs	21-Mar-19	F	4202131	TUB		UG
130083	Repair Aftercooler	21-Mar-19	F	4202131	ENGINE		UG
130113	DT12, CHANGE OUT DPF UNIT	22-Mar-19	F	4202131	ENGINE	2255	UG
130262	Replace retarder actuator on tranny	24-Mar-19	F	4202131	TRANS		UG
130273	Replace Air con bracket and belts	25-Mar-19	F	4202131	ENGINE		UG
130020	DT, Carry out 250hr service as per attached sheet	27-Mar-19	F	4202131	250HR	2244	UG
130322	3 Monthly work order for daily services & minor repairs	1-Apr-19	F	4202131	WHOLE	2108	UG
132074	FIT SPLASH GUARD AS PER SERVICE BULLETIN LHDL20150511	9-Apr-19	F	4202131	FRAME		UG
132111	DT, Carry out 500hr service as per attached service sheet	12-Apr-19	F	4202131	500HR	2245	UG
132241	Overheating and Oil Leak	15-Apr-19	F	4202131	ENGINE		UG
132512	Replace fan belt idler pivot bushing	20-Apr-19	F	4202131	ENGINE		UG
132670	Replace fan hub.	24-Apr-19	F	4202131	ENGINE		UG
132576	DT, Carry out 250hr service as per attached sheet	27-Apr-19	F	4202131	250HR	2244	UG
132698	Replace blown manifold gasket	27-Apr-19	F	4202131	ENGINE		UG
132839	HYDRAULIC OIL TEMPERATURE GAUGE NOT WORKING	2-May-19	F	4202131	HYD		UG
132970	REPAIR LATCH ON THE DOOR	3-May-19	F	4202131	CABIN		UG
132980	REMOVE AND REPLACE SEAT BELT	3-May-19	F	4202131	CABIN		UG
133176	Hydraulic leak on top of front Differential	6-May-19	F	4202131	HYD		UG
133289	Fan Bearings collapsed	9-May-19	F	4202131	ENGINE		UG
133327	Replace Fan Belts. Incorrect Belts Fitted	10-May-19	F	4202131	ENGINE		UG
132712	DT, Carry out 2000hr service as per attached sheet	12-May-19	F	4202131	2000HR	2247	UG
133521	AFFF Module Repairs	14-May-19	F	4202131	AFFF		UG
133554	replace all 4 tyres	14-May-19	F	4202131	TYRE		UG
134075	Dropbox warning light present	27-May-19	F	4202131	DRIVE		UG
134097	Replace Drive belts and tensioner.	27-May-19	F	4202131	ENGINE		UG
134146	ENGINE COOLANT AND EXHAUST MANIFOLD LEAK	28-May-19	F	4202131	ENGINE		UG
134249	REPLACE CRACKED REAR CAB WINDOW	10-Jun-19	F	4202131	CABIN		UG
134318	ENGINE HATCH/COVER NOT SECURED	10-Jun-19	F	4202131	FRAME		UG
134343	DT, Carry out 250hr service as per attached sheet	12-Jun-19	F	4202131	250HR	2244	UG
135346	Replace exhaust manifolds - leaking	21-Jun-19	F	4202131	ENGINE		UG
135551	Replace brake cooling pump hose.	23-Jun-19	F	4202131	HOSES		UG
135516	DT, Carry out 500hr service as per attached service sheet	25-Jun-19	F	4202131	500HR	2245	UG
135600	Brake Lights u/s	26-Jun-19	F	4202131	ELECTL		UG
135986	engine warning light	29-Jun-19	F	4202131	ENGINE		UG
136015	Blown Hydraulic hose	30-Jun-19	F	4202131	HOSES		UG
135812	Yearly work order for daily services & minor repairs	1-Jul-19	F	4202131	WHOLE	2108	UG
136664	Upbox Temperature fault	3-Jul-19	F	4202131	ELECTL		UG
136695	Replace Seat Switch	4-Jul-19	F	4202131	CABIN		UG
137806	Replace hyd oil level sensor	7-Jul-19	F	4202131	ELECTL		UG
137843	Replace air cleaner lid x 1 - Borrowed from DT14 box	8-Jul-19	F	4202131	ENGINE		UG
135972	DT, Carry out 250hr service as per attached sheet	11-Jul-19	F	4202131	250HR	2244	UG
137966	replace hyd hose under cab	11-Jul-19	F	4202131	HOSES		UG
136692	REPLACE TANK COVERS THAT DON'T SPRING RETURN	12-Jul-19	F	4202131	WHOLE		UG

137694	Replace L.H. steering kick out valve	12-Jul-19	F	4202131	STEER		UG
137988	Starter motor u/s	13-Jul-19	F	4202131	ELECTL		UG
138041	Low power issue	15-Jul-19	F	4202131	DRIVE		UG
137693	Replace door check strap	18-Jul-19	F	4202131	CABIN		UG
138139	Replace side window, Delay when service brake applied,	18-Jul-19	F	4202131	GLASS		UG
138404	Replace Fuel Level Switch	26-Jul-19	F	4202131	ELECTL		UG
138540	Fan Belts	28-Jul-19	F	4202131	ENGINE		UG
139054	FIND AND FIX COOLANT LEAKS	31-Jul-19	F	4202131	ENGINE		UG
138454	DT, Carry out 1000hr sevice as per attatched sheet	6-Aug-19	F	4202131	1000HR	2246	UG
139322	Replace cover to operator seat	6-Aug-19	F	4202131	CABIN		UG
139482	C/out flat pos 1 tyre	7-Aug-19	F	4202131	TYRE		UG
139690	C/out A/C belts	11-Aug-19	F	4202131	ACON		UG
139727	DT, CHANGE OUT OF LEFT SUSPENSION CYLINDER	12-Aug-19	F	4202131	AXLE	2618	UG
139781	Replace A/C Compressor and hoses.	14-Aug-19	F	4202131	ACON		UG
138414	FIT NEW DOOR STRIKER AS PER TECHNICAL SERVICE BULLETIN	16-Aug-19	F	4202131	CABIN		UG
139053	STRAIGHTEN DOOR ON CAB	16-Aug-19	F	4202131	CABIN		UG
139906	RH steer hose u/s	17-Aug-19	F	4202131	HOSES		UG
140039	Cabin damage from wall impact	21-Aug-19	F	4202131	WHOLE		UG
140304	Replace pos1 & 2 tyres	25-Aug-19	F	4202131	TYRE		UG
139931	DT, Carry out 250hr service as per attatched sheet	26-Aug-19	F	4202131	250HR	2244	UG
140306	driveline repairs	26-Aug-19	F	4202131	DRIVE		UG
140622	Replace hydraulic oil cooler	31-Aug-19	F	4202131	HYD		UG
141002	C/out aftercooler gasket and hose	31-Aug-19	F	4202131	ENGINE		UG
141177	Engine Oil Leak	5-Sep-19	F	4202131	ENGINE		UG
139895	REPLACE AIR-CON MOUNTING BRACKET	6-Sep-19	F	4202131	ACON		UG
141102	Replace turbo - leaking gases	9-Sep-19	F	4202131	ENGINE		UG
141861	Repair engine oil leak	11-Sep-19	F	4202131	HOSES		UG
140439	Install Digital Radio	14-Sep-19	F	4202131	ELECTL		UG
141935	Engine oil leak.	14-Sep-19	F	4202131	ENGINE		UG
142055	Driveline repairs	15-Sep-19	F	4202131	DRIVE		UG
142085	Exhaust clamp failure & AFFF detection line set-off	16-Sep-19	F	4202131	ENGINE		UG
142315	A/C Fan U/S	20-Sep-19	F	4202131	ACON		UG
142475	Turbo Fault	21-Sep-19	F	4202131	ENGINE		UG
142053	Repair broken bolts at hyd tank breather/ filter	22-Sep-19	F	4202131	HYD		UG
142576	Seat pump u/s under load	25-Sep-19	F	4202131	CABIN		UG
142657	DT, Carry out 500hr service as per attatched service sheet	27-Sep-19	F	4202131	500HR	2245	UG
141768	Install manifold back pressure kit as per vendor instruction	28-Sep-19	I	4202131	ENGINE		UG
142862	Replace Gear Selector	28-Sep-19	F	4202131	ELECTL		UG
142880	C/out dropbox cooler fan	29-Sep-19	F	4202131	ELECTL		UG
142165	Repair windscreen washers - pump	30-Sep-19	F	4202131	ELECTL		UG
142274	Replace rusted air cleaner	30-Sep-19	F	4202131	ENGINE		UG
143033	Carry out fire suppression service	7-Oct-19	F	4202131	AFFF	2227	UG
143521	C/out blown hydraulic hose	10-Oct-19	F	4202131	HOSES		UG
143719	Turbo flange gasket failed.	13-Oct-19	F	4202131	ENGINE		UG
143337	Repair door check	16-Oct-19	F	4202131	CABIN		UG
143752	FIT NEW UPDATED MANIFOLD GARD (LAGGING) TO EXHAUST AND TURBO	16-Oct-19	F	4202131	ENGINE		UG
143871	Replace Broken Door Window	18-Oct-19	F	4202131	CABIN		UG
143875	Drop Box Light Coming On.	18-Oct-19	F	4202131	DRIVE		UG
143673	DT, Carry out 250hr service as per attatched sheet	21-Oct-19	F	4202131	250HR	2244	UG
144406	Replace brake cooling pipe - leaking	22-Oct-19	F	4202131	BRAKE		UG
144411	Refurbish Tub Off DT06	22-Oct-19	F	4202131	TUB		UG
143493	Replace bushes at front axle torque rod	27-Oct-19	S	4202131	AXLE		UG
144857	C/out faulty AFFF bottle head	29-Oct-19	F	4202131	AFFF		UG
144958	Engine Overheating. Broken fan Belts	31-Oct-19	F	4202131	ENGINE		UG
144960	Pos 2 Tyre Flat	1-Nov-19	F	4202131	TYRE		UG
145185	C/out blown o rings on steering pump hoses	1-Nov-19	F	4202131	HOSES		UG
145363	DT, Carry out 2000hr service as per attatched sheet	11-Nov-19	F	4202131	2000HR	2247	UG
145427	Repair "gear selectable with park brake applied" fault	11-Nov-19	F	4202131	ELECTL		UG
145890	Oversized bundy loaded causing machine damage	12-Nov-19	F	4202131	WHOLE		UG
146467	replace u/s grease pump	17-Nov-19	F	4202131	WHOLE		UG
146853	Blown A/C Hose	24-Nov-19	F	4202131	ACON		UG
146955	C/out tranny computer due to truck selecting gears while the	25-Nov-19	F	4202131	ELECTL		UG
146993	FUEL GAUGE IN CAB REPORTED NOT TO BE WORKING	26-Nov-19	F	4202131	ELECTL		UG
147017	change out pos 2 steer cylinder	27-Nov-19	F	4202131	HYDCYL		UG
147029	check operation of air con, reported to be warm	27-Nov-19	F	4202131	ACON		UG
147037	a/c is too hot. repair as required	27-Nov-19	F	4202131	ACON		UG
147165	Weld up cracks on Tub	29-Nov-19	F	4202131	TUB		UG

147585	C/out Idler bearings	30-Nov-19	F	4202131	ENGINE		UG
147795	C/out and reseal retarder valve	3-Dec-19	F	4202131	TRANS		UG
147910	Retarder coming on continuously - PLC u/s	5-Dec-19	F	4202131	ELECTL		UG
147149	Check and replace horn if necessary reported not loud.	6-Dec-19	F	4202131	ELECTL		UG
147004	Replace A frame bolts	12-Dec-19	F	4202131	FRAME		UG
DT1220	Daily Consumables Only	1-Jan-20	F	4202131	WHOLE		UG
153160	C/out reverse camera and cable	16-Feb-20	F	4202131	ELECTL		UG
153161	repalce DPF	16-Feb-20	F	4202131	ENGINE		UG
153247	inspect noise from left hand side of truck	18-Feb-20	F	4202131	WHOLE		UG
153345	Park Barke Coming On Intermittently	20-Feb-20	F	4202131	BRAKE		UG
153402	Park brake fault - not releasing	21-Feb-20	F	4202131	BRAKE		UG
153414	Repair transmission fault - getting stuck in gear	22-Feb-20	F	4202131	ELECTL		UG
153657	Repairs to top left side of tub - split open from one end to	24-Feb-20	F	4202131	TUB		UG
148134	DT, Carry out 500hr service as per attached service sheet	2-Mar-20	I	4202131	500HR	2245	UG

Specifications

Capacities	
SAE regulations	
Tramming capacity	60 000 kg

Motion times	
Dump box	
Dumping	15 seconds

Engine

- Cummins.....QSK19-C760, Tier 1/Stage I A
- Power Rating at 2100 rpm..... 567 kW/760 hp
- Maximum torque at 1300 rpm..... 3 084 Nm
- MSHA Part 7 ventilation rate TBA
- Ventilation particulate index TBA
- Rock Tough purifier and silencer.
- Dry type air cleaner.
- Exhaust heat protection.
- Remote engine oil drain.
- Cooling package with flat, round, mechanical radiator.

Transmission and converter

- Planetary, automatic 6 speeds forward/2 speeds reverse with integral single stage converter with automatic lock up.
- Allison.....M6610AR
- Up box: Power transmitted through a 1:1 gear ratio box.
- Drop box: Power transmitted through a 1:1 gear ratio box.

Axles

- Kessler 111
- Conventional front and rear differential.
- Front-axle oscillating suspension "A" frame with hydraulic suspension cylinders and accumulator cushioning.
- All wheel drive.

Brakes

- Fully enclosed, force cooled, multiple wet discs at each wheel end.
- Service/parking/emergency brakes SAHR
 - Hydraulic retarder.



The MT6020 is standard equipped with a rear vision camera. A small detail, but definitely worth viewing - is the standard equipped camera for improved operator's visibility.

Tyres

- Tubeless, steel radial, lug tread design for underground mine service.
- Dimensions 35/65, R33*
- * As applications and conditions vary, Atlas Copco recommends that the user consults with tyre suppliers to obtain the optimum tyre selection.

Suspension

- The suspension is a gas-hydraulic system for improved operator comfort and vehicle handling while minimizing frame stress.
- Suspension, max: 105 mm
 - Individual self leveling suspension.

Operator's compartment

- Forward facing seat.
- Cabin; MSHA-ISO ROPS/FOPS approved.
- Grammer seat with retractable seat belts.
- Airconditioner.
- Trainer seat.
- Back up video monitor.

Hydraulic system

- System pressure 20.7 MPa
- Hydraulic tank capacity 238 litres
- Filtration, return line 4.0 µm
- Heavy duty gear type pumps.
- Cylinders diameter:
 - Steer cylinders (2) 160 mm
 - Dump cylinders (2) 177.8 mm
 - Suspension cylinders (2) 125 mm

Electrical system

- Voltage, system start & accessories 24 V
- Alternator, high output 100 A
- Hydraulic warning system; temperature, hyd. oil level.
- Rock Tough projection lights.
- Isolation switch lockout.

Fuel

- Fuel tank capacity 644 litres
- Fuel consumption, full load 67 litres/hour
- Fuel filtration 10 µm
- Anti-siphon fuel supply.

Turning radius

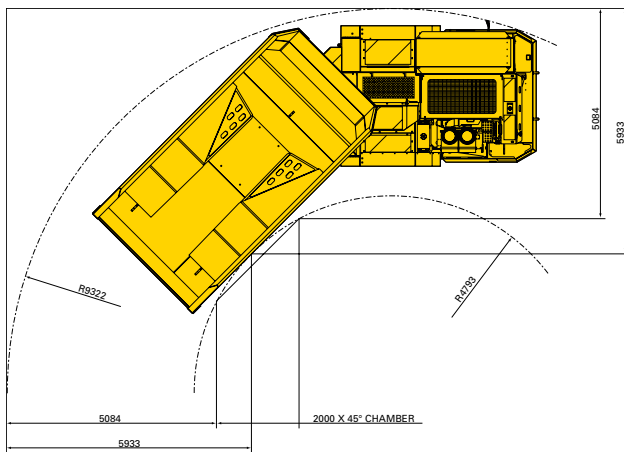

Recommended drift size

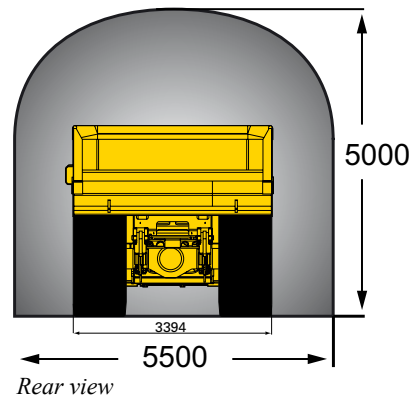

- Turning angle +/-42.5°.
- Dimensions shown are based on standard vehicle configuration with 27 mm tyre deflection.
- All dimensions are shown in millimetres.

Grade performance

NB. 3% rolling resistance assumed. Actual performance may vary depending on the application.

Standard configuration, box empty

Percent grade	0.0	2.0	4.0	6.0	8.0	10.0	12.0	14.0	16.0	18.0	20.0
Ratio					1:12	1:10	1:8	1:7			1:5
1st gear (km/h)	6.4	6.4	6.3	6.3	6.3	6.3	6.3	6.3	6.3	6.3	6.3
2nd gear (km/h)	9.5	9.5	9.4	9.4	9.4	9.4	9.3	9.3	9.3	9.3	9.2
3rd gear (km/h)	12.6	12.6	12.5	12.5	12.4	12.4	12.4	12.3	12.3	12.2	12.2
4th gear (km/h)	18.3	18.2	18.2	18.1	18.0	17.9	17.8	17.7	17.6	17.5	17.1
5th gear (km/h)	25.2	25.1	24.9	24.7	24.5	24.3	24.2	23.2	21.2		
6th gear (km/h)	37.5	37.1	36.7	36.3	35.6	30.9					

Standard configuration, box loaded

Percent grade	0.0	2.0	4.0	6.0	8.0	10.0	12.0	14.0	16.0	18.0	20.0
Ratio					1:12	1:10	1:8	1:7			1:5
1st gear (km/h)	6.3	6.3	6.3	6.2	6.2	6.2	6.2	6.1	6.1	6.1	6.0
2nd gear (km/h)	9.4	9.3	9.3	9.2	9.2	9.1	9.0	9.0	8.3	7.3	
3rd gear (km/h)	12.5	12.4	12.3	12.2	12.1	11.9	10.6				
4th gear (km/h)	18.1	17.9	17.6	17.2	13.5						
5th gear (km/h)	24.8	24.3	22.5								
6th gear (km/h)	36.5	31.7									

Optional equipment

Main frame

- Wheel chocks and chock brackets.
- Tele dump

Ergonomic

- KAB 555 seat W/retractable seatbelts.
- Heater

System

- Ansul dual bottle fire suppression with Engine kill.
- Electric hydraulic tank fill pump.
- Dual fuel filter.

- Lincoln auto lube with timer.
- Wiggins fast fuel-, transmission-, hydraulic- oil fill.

Electrical system

- Amber strobe light - power on.
- Load lights.
- Side light opposite operator.
- Tail and brake lights.
- Turn signals, front and rear.
- 24/12 V power converter.
- Loading camera.
- Battery heater, 120 V.
- Block heater, 120 V.
- Hydraulic oil heater, 120 V.

- Engine oil heater, 120 V.

- Diesel Filter with heater and water separation (7 micron).
- Fire extinguisher (20 LB)

Drive train

- Neutral brake apply.

Controls and instruments

- Blockout 5th and/or 6th gears.
- Emergency steering- accumulator type.
- Extended data gauge package.

Power unit

- Epoxy coated radiator.

Documentation

- LinkOne parts catalogue, CD.
- Parts and service manual - plasticised.

Parts kit

- 1 000 hour consumables.

Other

- Tool box.

Dump boxes

Dump box data		STD			
Material density (t/m ³)	1.8	2.0	2.2	2.4	
Volume, SEA struck (m ³)	30.4	26.6	24.1	21.7	
Volume, Semi-heaped (m ³)	33.3	29.7	27.3	25.0	
Volume, SAE heaped (m ³)	36.3	32.8	33.4	28.2	
Width, dump box (mm)	W	3 440	3440	3440	3440
Dump position: Box height, max (mm)	H1	6909	6842	6750	6689
Tramming position: Dump box height (mm)	H2	3462	3263	3122	2993
Dump position: Clearance (mm)	C	471	471	471	471

Dimensions and weights

Approximate net weight.....43 900 kg
 Axle load, front end29 700 kg
 Axle load, back end.....14 200 kg

Standard equipped vehicle with empty box.

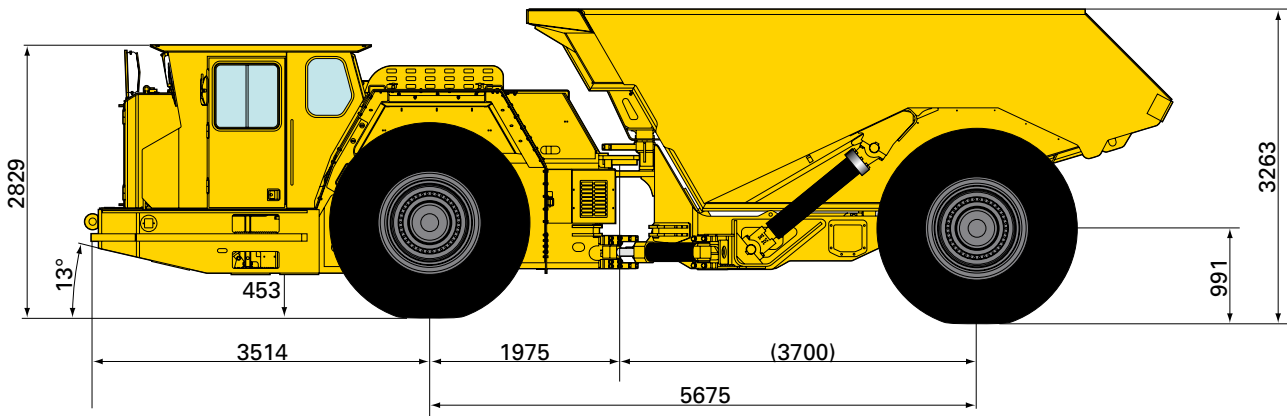

Side view

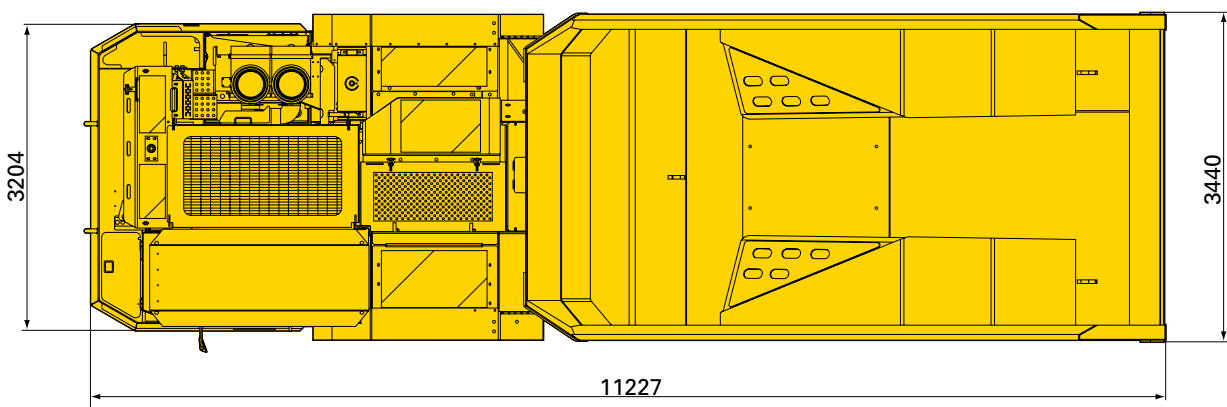

Top view

- Dimensions shown are based on standard vehicle configuration with 27 mm tyre deflection.
- All dimensions are shown in millimetres.



© Copyright 2007, Atlas Copco Rock Drills AB, Örebro, Sweden. Any unauthorized use or copying of the contents or any part thereof is prohibited. This applies in particular to trademarks, model denominations, part numbers and drawings. Illustrations and photos in this brochure may show equipment with optional extras. Specifications and equipment subjects to change without notice. Consult your Atlas Copco Customer Center for specific information.