

**2011 Atlas Copco MT6020 DT013, UT13**



<b>Make</b>	Atlas Copco		<b>Model</b>	MT6020		
<b>Year</b>	2011	<b>Hours</b>	20783		As at	01/04/2021
<b>Mileage</b>					km	As at
<b>Serial/VIN</b>	AVO11X431-150			<b>Engine Serial</b>		
<b>Details</b>	Un Reserved 2011 Atlas Copco MT6020 Asset DT013,_UT13. Offered for sale via Online auction in "As Is" condition, running to drive on to buyers transport. Located at Savannah Nickel Mine, via Kununurra Western Australia.					
<b>Asking price</b>	AUD	Under review - call for pricing				
<b>Ex site</b>	Australia, Western Australia, Kununurra					

<b>Service history</b>	
------------------------	--

**For further details, to make an offer or book an inspection, contact  
Global Equipment Solutions on Office: 08 9201 1142**

















Work Order	Description	Start Date	Status	Cost Centre	Key/Section	PM Task	Branch
140245	REPLACE CRACKED WINDOWS	2-Sep-18	F	4202131	CABIN		UG
117919	DT, Carry out 500hr service as per attached service sheet	9-Sep-18	F	4202131	500HR	2245	CAP
117949	Carry out fire suppression service	11-Sep-18	F	4202131	AFFF	2227	CAP
117972	3 Monthly work order for daily services & minor repairs	1-Oct-18	F	4202131	WHOLE	2108	CAP
117993	Replace corroded air filter housing	4-Oct-18	F	4202131	ENGINE		CAP
117997	REPLACE LEAKING BRAKE/AUXILLARY PLATE GASKETS	27-Oct-18	F	4202131	ENGINE		CAP
118238	Replace both fuel manifolds due to leaking	4-Nov-18	F	4202131	ENGINE		CAP
118166	FIT REAR AND SIDE CAMERA KIT AS PER MINING REQUEST	12-Nov-18	F	4202131	ELECTL		CAP
118343	DT, Carry out 1000hr service as per attached sheet	19-Nov-18	F	4202131	1000HR	2246	CAP
118321	DT, Carry out 125HR inspection as per attached sheet	22-Nov-18	L	4202131	125HR	2243	CAP
118406	No Gears	25-Nov-18	F	4202131	ELECTL		CAP
118507	DT, Carry out 250hr service as per attached sheet	9-Dec-18	F	4202131	250HR	2244	CAP
123319	Repair damage from truck hitting the wall	26-Dec-18	F	4202131	WHOLE		CAP
123500	REPLACE BLOWN POS 3 TYRE	31-Dec-18	F	4202131	TYRE		CAP
123256	DT, Carry out 500hr service as per attached service sheet	31-Dec-18	F	4202131	500HR	2245	CAP
123276	3 Monthly work order for daily services & minor repairs	1-Jan-19	F	4202131	WHOLE	2108	CAP
123512	REPAIR DAMAGE FROM THE TRUCK HITTING THE WALL	3-Jan-19	F	4202131	FRAME		CAP
123530	3 Monthly work order for daily services & minor repairs	6-Jan-19	F	4202131	WHOLE	2108	CAP
123534	REPLACE BROKEN CAB DOOR WINDOW	7-Jan-19	F	4202131	CABIN		CAP
123843	DT, Carry out 250hr service as per attached sheet	18-Jan-19	F	4202131	250HR	2244	CAP
125755	Repair leaking POS 2 tyre	24-Jan-19	F	4202131	RIM		CAP
125684	Replace leaking valves on suspension valve block	31-Jan-19	F	4202131	HYD		CAP
125935	REPLACE CRACKED REAR GLASS WINDOW IN THE CAB	1-Feb-19	F	4202131	GLASS		CAP
126872	Replace steer cylinder pin and Hyd return filter	7-Feb-19	F	4202131	STEER		CAP
1268891	check tension of steering cylinder cap bolts	8-Feb-19	F	4202131	FRAME		UG
126917	TEST PARK BRAKE SYSTEM AS PER MANUFACTURES GUIDLINES	9-Feb-19	F	4202131	BRAKE		UG
126941	INVESTIGATE POSSIBLE FIRE NEAR FUEL TANK	9-Feb-19	F	4202131	ENGINE		CAP
125968	DT, Carry out 2000hr service as per attached sheet	12-Feb-19	F	4202131	2000HR	2247	CAP
127797	Replace Transmission spider harness	21-Feb-19	F	4202131	ELECTL		UG
128907	INSPECT THE FUEL TANK BREATHER IS NOT POINTING TOWARD THE	2-Mar-19	F	4202131	ENGINE		UG
128631	REPLACE AC DRYER AND CAB FILTER- CHECK SYSTEM FOR CORRECT	6-Mar-19	F	4202131	ACON		UG
129208	DT, Carry out 250hr service as per attached sheet	6-Mar-19	F	4202131	250HR	2244	UG
129313	Replace front tailshaft centre bearing	8-Mar-19	F	4202131	DRIVE		UG
129319	remove broken engine mount bolts	9-Mar-19	F	4202131	FRAME		UG
129223	Carry out fire suppression service	11-Mar-19	F	4202131	AFFF	2227	UG
129548	Replace pos 1 Tyre u/s	14-Mar-19	F	4202131	TYRE		UG
129628	Split In Fuel Tank C/O Top Cooler Bush	17-Mar-19	F	4202131	ENGINE		UG
129994	check low power issue	18-Mar-19	F	4202131	ENGINE		UG
129985	Replace leaking engine oil remote filter hose	19-Mar-19	F	4202131	ENGINE		UG
130092	Blown Hose Under Cab	21-Mar-19	F	4202131	HOSES		UG
130263	Temp repair leaking hyd tank with devcon	24-Mar-19	F	4202131	HYD		UG
130021	DT, Carry out 500hr service as per attached service sheet	25-Mar-19	F	4202131	500HR	2245	UG
130359	Replace transmission shifter	26-Mar-19	F	4202131	TRANS		UG
130118	Replace remote oil filter hoses	28-Mar-19	F	4202131	ENGINE		UG
130323	3 Monthly work order for daily services & minor repairs	1-Apr-19	F	4202131	WHOLE	2108	UG
131884	REPLACE LEAKING HYDRAULIC HOSE	2-Apr-19	F	4202131	HYD		UG
131980	repair damage to air filter housing.	5-Apr-19	F	4202131	WHOLE		UG
130117	Replace corroded hydraulic tank	6-Apr-19	F	4202131	FRAME		UG
130443	Replace leaking retarder pedal	7-Apr-19	F	4202131	HYD		UG
132075	FIT SPLASH GUARD AS PER SERVICE BULLETIN LHDL20150511	9-Apr-19	F	4202131	FRAME		UG
132081	LOW OIL UPBOX - DROPBOX	9-Apr-19	F	4202131	DRIVE		UG
132120	Replace all tyres	9-Apr-19	F	4202131	TYRE		UG
132125	REPLACE BROKEN AIR FILTER PRE-CLEANERS	19-Apr-19	L	4202131	ENGINE		UG
132529	Brake Pedal Leaking	20-Apr-19	F	4202131	BRAKE		UG
132577	DT, Carry out 250hr service as per attached sheet	23-Apr-19	F	4202131	250HR	2244	UG
132975	STEERING FAULT	2-May-19	F	4202131	STEER		UG
133010	NO AERIAL - COMMS BAD	4-May-19	F	4202131	ELECTL		UG
133024	cab fan blowing circuit breaker	4-May-19	F	4202131	ACON		UG
133125	repair exhaust leaks and repairs	5-May-19	F	4202131	ENGINE		UG
133013	AIR-CONDITIONING NOT WORKING	6-May-19	F	4202131	ACON		UG
132734	REPLACE BROKEN DIPSTICK TUBE	7-May-19	F	4202131	TRANS		UG
133228	TRUCK RIDING ROUGH	7-May-19	F	4202131	HYD		UG
133290	Replace missing fire extinguisher and bracket	9-May-19	F	4202131	FRAME		UG
132713	DT, Carry out 1000hr service as per attached sheet	12-May-19	F	4202131	1000HR	2246	UG

133519	replace steer cylinder pin	13-May-19	F	4202131	STEER		UG
133284	REPLACE EXHAUST MANIFOLDS AND GASKETS	18-May-19	F	4202131	ENGINE		UG
134017	DT, Carry out 250hr service as per attached sheet	30-May-19	F	4202131	250HR	2244	UG
134533	Remove and Replace Steel Tube On Brakes	4-Jun-19	F	4202131	BRAKE		UG
134551	CHANGE OUT ENGINE COVER GAS STRUTS	10-Jun-19	F	4202131	FRAME		UG
134901	A/C Not Cold	13-Jun-19	F	4202131	ACON		UG
134553	REPLACE U/S LEFT HAND REAR ENGINE MOUNT	15-Jun-19	F	4202131	ENGINE		UG
135300	AFFF Low Pressure	18-Jun-19	F	4202131	AFFF		UG
134921	DT, Carry out 500hr service as per attached service sheet	19-Jun-19	F	4202131	500HR	2245	UG
135503	Transmission temperature guage fluctuating	21-Jun-19	F	4202131	ELECTL		UG
135813	Yearly work order for daily services & minor repairs	1-Jul-19	F	4202131	WHOLE	2108	UG
136665	Transmission warning light on	3-Jul-19	F	4202131	ELECTL		UG
135505	Replace door seal. HazID 63639	11-Jul-19	F	4202131	CABIN		UG
138243	Replace trim boost solenoid gasket.	20-Jul-19	L	4202131	TRANS		UG
138270	Replace centre bearing.	21-Jul-19	F	4202131	DRIVE		UG
138430	Fuel Leak At Tank	26-Jul-19	F	4202131	FRAME		UG
139334	Engine Stopped Will Not Start	4-Aug-19	F	4202131	ENGINE		UG
139496	Park Brake Fault	8-Aug-19	F	4202131	BRAKE		UG
139500	C/out rear camera	8-Aug-19	F	4202131	ELECTL		UG
139668	Replace A/C fan.	10-Aug-19	F	4202131	ACON		UG
139877	C/out dropbox level sensor	14-Aug-19	F	4202131	ELECTL		UG
138415	FIT NEW DOOR STRIKER AS PER TECHNICAL SERVICE BULLETIN	16-Aug-19	F	4202131	CABIN		UG
139579	Wash engine and identify cause of oil leak	16-Aug-19	F	4202131	ENGINE		UG
139755	DT, Carry out 250hr service as per attached sheet	16-Aug-19	F	4202131	250HR	2244	UG
140042	Replace drive belts	22-Aug-19	F	4202131	ENGINE		UG
139769	Replace brake release lever	24-Aug-19	F	4202131	CABIN		UG
140281	Blown Hose Hoist Pump To Control Valve	24-Aug-19	F	4202131	HOSES		UG
140614	Up Box Cooler Leaking	31-Aug-19	F	4202131	DRIVE		UG
141017	C?out dropbox level sensor	1-Sep-19	F	4202131	ELECTL		UG
141111	C/out Exhaust Manifold	3-Sep-19	F	4202131	ENGINE		UG
140256	DT, Carry out 2000hr service as per attached sheet	5-Sep-19	F	4202131	2000HR	2247	UG
141174	Steering Heavy	5-Sep-19	F	4202131	STEER		UG
141723	No Drive.	8-Sep-19	F	4202131	DRIVE		UG
141726	Tow DT13 from 1540 to surface.	8-Sep-19	F	4202131	DRIVE		UG
141760	Repair leak at hydraulic oil tank cover	11-Sep-19	F	4202131	HYD		UG
141860	DT, CHANGE OUT OF UP-BOX COUPLING ONLY	11-Sep-19	F	4202131	TRANS	3550	UG
141747	Investigate and report on heavy steering	12-Sep-19	F	4202131	STEER		UG
140440	Install Digital Radio	15-Sep-19	F	4202131	ELECTL		UG
142138	DT, CHANGE OUT OF UP-BOX	16-Sep-19	F	4202131	TRANS	2657	UG
142478	Charge Fault	21-Sep-19	F	4202131	ELECTL		UG
142501	Park Brake Stuck On	22-Sep-19	F	4202131	BRAKE		UG
142549	Replace UpBox Assy	24-Sep-19	F	4202131	TRANS		UG
142140	Replace fuel tank breather	30-Sep-19	I	4202131	ENGINE		UG
142187	Replace air cleaner covers	30-Sep-19	F	4202131	ENGINE		UG
142816	Carry out fire suppression service	2-Oct-19	F	4202131	AFFF	2227	UG
143091	Check Engine Light Coming On	4-Oct-19	F	4202131	ELECTL		UG
143392	Re-install door window	9-Oct-19	F	4202131	CABIN		UG
143471	Fuel gauge reading incorrectly.	10-Oct-19	F	4202131	CABIN		UG
143570	Fuel tank leaking identify source.	12-Oct-19	F	4202131	FRAME		UG
143731	C/out tub proximity switch	13-Oct-19	F	4202131	ELECTL		UG
143732	Engine oil blowby from engine	13-Oct-19	F	4202131	ENGINE		UG
143279	DT, Carry out 250hr service as per attached sheet	18-Oct-19	F	4202131	250HR	2244	UG
144682	C/out steer cylinder	26-Oct-19	F	4202131	HYDCYL		UG
143549	FLYWHEEL HOUSING NEEDS REPLACING.	26-Oct-19	S	4202131	ENGINE		UG
144793	Diagnose and repair park brake fault	27-Oct-19	F	4202131	ELECTL		UG
144847	Tub Alarm Fault. PLC U/S	28-Oct-19	F	4202131	ELECTL		UG
145299	C/out engine belt	3-Nov-19	F	4202131	ENGINE		UG
145601	Repair aircon system - hose rubbed through	7-Nov-19	F	4202131	ACON		UG
145797	Fan Belts u/s	10-Nov-19	F	4202131	ENGINE		UG
145658	DT, Carry out 500hr service as per attached service sheet	11-Nov-19	F	4202131	500HR	2245	UG
145554	Repair oil leak at water pump	12-Nov-19	F	4202131	ENGINE		UG
145934	Steering articulation hose blown	13-Nov-19	F	4202131	STEER		UG
145938	Repair tear in tub.	13-Nov-19	F	4202131	TUB		UG
144951	Replace engine mounts	15-Nov-19	I	4202131	ENGINE		UG
146408	Upbox cooler hose u/s	15-Nov-19	F	4202131	HOSES		UG

146492	Turbo Leak	17-Nov-19	F	4202131	ENGINE		UG
146801	C/out seat switch	22-Nov-19	F	4202131	CABIN		UG
146844	INSPECT AND REPAIR ENGINE OVERHEATING FAULT	23-Nov-19	F	4202131	ENGINE		UG
146851	Changed Out Battery Isolator On Daily Service.	23-Nov-19	F	4202131	ELECTL		UG
147136	A/C Compressor Failed	29-Nov-19	F	4202131	ACON		UG
145585	Refurbish PLC ex DT13	30-Nov-19	S	4202131	ELECTL		UG
146864	DT, Carry out 250hr service as per attached sheet	30-Nov-19	F	4202131	250HR	2244	UG
147618	Truck blocking decline at SP3	1-Dec-19	F	4202131	ENGINE		UG
147631	C/o blown o ring seal on brake cooling line	1-Dec-19	F	4202131	BRAKE		UG
146804	Replace exhaust guarding ( blanket lagging)	11-Dec-19	I	4202131	ENGINE		UG
147864	Repair oil leak at pos 2 wheel end	20-Dec-19	S	4202131	AXLE		UG
DT1320	Daily Consumables Only	1-Jan-20	F	4202131	WHOLE		UG



# Specifications

Capacities		Motion times	
SAE regulations		Dump box	
Tramming capacity	60 000 kg	Dumping	15 seconds

## Engine

- Cummins.....QSK19-C760, Tier 1/Stage I A
- Power Rating at 2100 rpm..... 567 kW/760 hp
- Maximum torque at 1300 rpm..... 3 084 Nm
- MSHA Part 7 ventilation rate ..... TBA
- Ventilation particulate index ..... TBA
- Rock Tough purifier and silencer.
- Dry type air cleaner.
- Exhaust heat protection.
- Remote engine oil drain.
- Cooling package with flat, round, mechanical radiator.

## Transmission and converter

- Planetary, automatic 6 speeds forward/2 speeds reverse with integral single stage converter with automatic lock up.
- Allison.....M6610AR
- Up box: Power transmitted through a 1:1 gear ratio box.
- Drop box: Power transmitted through a 1:1 gear ratio box.

## Axles

- Kessler ..... 111
- Conventional front and rear differential.
- Front-axle oscillating suspension "A" frame with hydraulic suspension cylinders and accumulator cushioning.
- All wheel drive.

## Brakes

- Fully enclosed, force cooled, multiple wet discs at each wheel end.
- Service/parking/emergency brakes ..... SAHR
  - Hydraulic retarder.



The MT6020 is standard equipped with a rear vision camera. A small detail, but definitely worth viewing - is the standard equipped camera for improved operator's visibility.

## Tyres

- Tubeless, steel radial, lug tread design for underground mine service.
- Dimensions ..... 35/65, R33\*
- \* As applications and conditions vary, Atlas Copco recommends that the user consults with tyre suppliers to obtain the optimum tyre selection.

## Suspension

- The suspension is a gas-hydraulic system for improved operator comfort and vehicle handling while minimizing frame stress.
- Suspension, max: ..... 105 mm
  - Individual self leveling suspension.

## Operator's compartment

- Forward facing seat.
- Cabin; MSHA-ISO ROPS/FOPS approved.
- Grammer seat with retractable seat belts.
- Airconditioner.
- Trainer seat.
- Back up video monitor.

## Hydraulic system

- System pressure ..... 20.7 MPa
- Hydraulic tank capacity ..... 238 litres
- Filtration, return line ..... 4.0 µm
- Heavy duty gear type pumps.
- Cylinders diameter:
  - Steer cylinders (2) ..... 160 mm
  - Dump cylinders (2) ..... 177.8 mm
  - Suspension cylinders (2) ..... 125 mm

## Electrical system

- Voltage, system start & accessories ..... 24 V
- Alternator, high output ..... 100 A
- Hydraulic warning system; temperature, hyd. oil level.
- Rock Tough projection lights.
- Isolation switch lockout.

## Fuel

- Fuel tank capacity ..... 644 litres
- Fuel consumption, full load ..... 67 litres/hour
- Fuel filtration ..... 10 µm
- Anti-siphon fuel supply.

## Turning radius

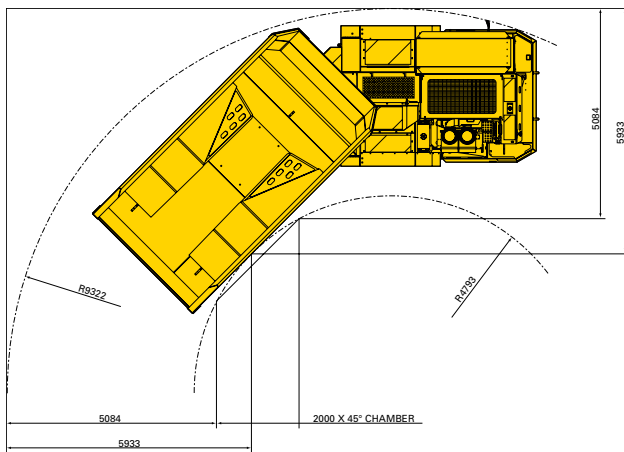

## Recommended drift size

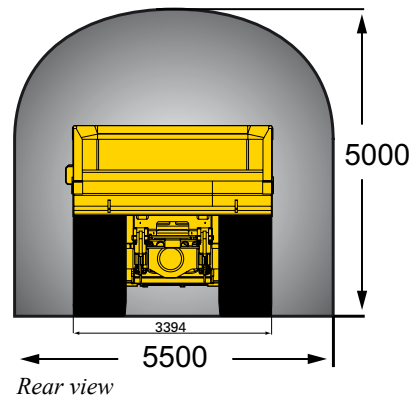

- Turning angle +/-42.5°.
- Dimensions shown are based on standard vehicle configuration with 27 mm tyre deflection.
- All dimensions are shown in millimetres.

## Grade performance

NB. 3% rolling resistance assumed. Actual performance may vary depending on the application.

### Standard configuration, box empty

Percent grade	0.0	2.0	4.0	6.0	8.0	10.0	12.0	14.0	16.0	18.0	20.0
Ratio					1:12	1:10	1:8	1:7			1:5
1st gear (km/h)	6.4	6.4	6.3	6.3	6.3	6.3	6.3	6.3	6.3	6.3	6.3
2nd gear (km/h)	9.5	9.5	9.4	9.4	9.4	9.4	9.3	9.3	9.3	9.3	9.2
3rd gear (km/h)	12.6	12.6	12.5	12.5	12.4	12.4	12.4	12.3	12.3	12.2	12.2
4th gear (km/h)	18.3	18.2	18.2	18.1	18.0	17.9	17.8	17.7	17.6	17.5	17.1
5th gear (km/h)	25.2	25.1	24.9	24.7	24.5	24.3	24.2	23.2	21.2		
6th gear (km/h)	37.5	37.1	36.7	36.3	35.6	30.9					

### Standard configuration, box loaded

Percent grade	0.0	2.0	4.0	6.0	8.0	10.0	12.0	14.0	16.0	18.0	20.0
Ratio					1:12	1:10	1:8	1:7			1:5
1st gear (km/h)	6.3	6.3	6.3	6.2	6.2	6.2	6.2	6.1	6.1	6.1	6.0
2nd gear (km/h)	9.4	9.3	9.3	9.2	9.2	9.1	9.0	9.0	8.3	7.3	
3rd gear (km/h)	12.5	12.4	12.3	12.2	12.1	11.9	10.6				
4th gear (km/h)	18.1	17.9	17.6	17.2	13.5						
5th gear (km/h)	24.8	24.3	22.5								
6th gear (km/h)	36.5	31.7									

## Optional equipment

### Main frame

- Wheel chocks and chock brackets.
- Tele dump

### Ergonomic

- KAB 555 seat W/retractable seatbelts.
- Heater

### System

- Ansul dual bottle fire suppression with Engine kill.
- Electric hydraulic tank fill pump.
- Dual fuel filter.

- Lincoln auto lube with timer.
- Wiggins fast fuel-, transmission-, hydraulic- oil fill.

### Electrical system

- Amber strobe light - power on.
- Load lights.
- Side light opposite operator.
- Tail and brake lights.
- Turn signals, front and rear.
- 24/12 V power converter.
- Loading camera.
- Battery heater, 120 V.
- Block heater, 120 V.
- Hydraulic oil heater, 120 V.

- Engine oil heater, 120 V.

- Diesel Filter with heater and water separation (7 micron).
- Fire extinguisher (20 LB)

### Drive train

- Neutral brake apply.

### Controls and instruments

- Blockout 5th and/or 6th gears.
- Emergency steering- accumulator type.
- Extended data gauge package.

### Power unit

- Epoxy coated radiator.

### Documentation

- LinkOne parts catalogue, CD.
- Parts and service manual - plasticised.

### Parts kit

- 1 000 hour consumables.

### Other

- Tool box.



# Dump boxes

Dump box data		STD			
Material density (t/m <sup>3</sup> )	1.8	2.0	2.2	2.4	
Volume, SEA struck (m <sup>3</sup> )	30.4	26.6	24.1	21.7	
Volume, Semi-heaped (m <sup>3</sup> )	33.3	29.7	27.3	25.0	
Volume, SAE heaped (m <sup>3</sup> )	36.3	32.8	33.4	28.2	
Width, dump box (mm)	W	3 440	3440	3440	3440
Dump position: Box height, max (mm)	H1	6909	6842	6750	6689
Tramming position: Dump box height (mm)	H2	3462	3263	3122	2993
Dump position: Clearance (mm)	C	471	471	471	471

## Dimensions and weights

Approximate net weight.....43 900 kg  
 Axle load, front end .....29 700 kg  
 Axle load, back end.....14 200 kg

*Standard equipped vehicle with empty box.*

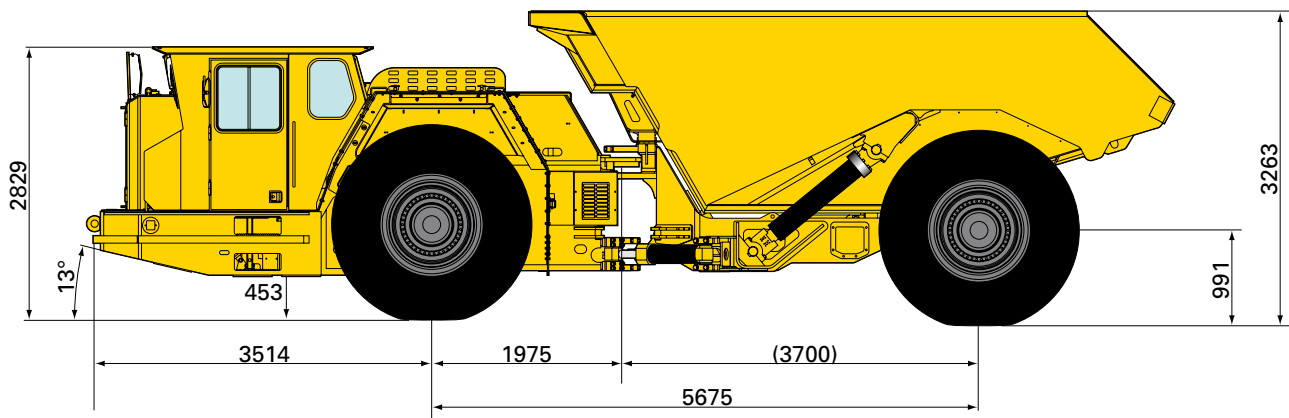

Side view

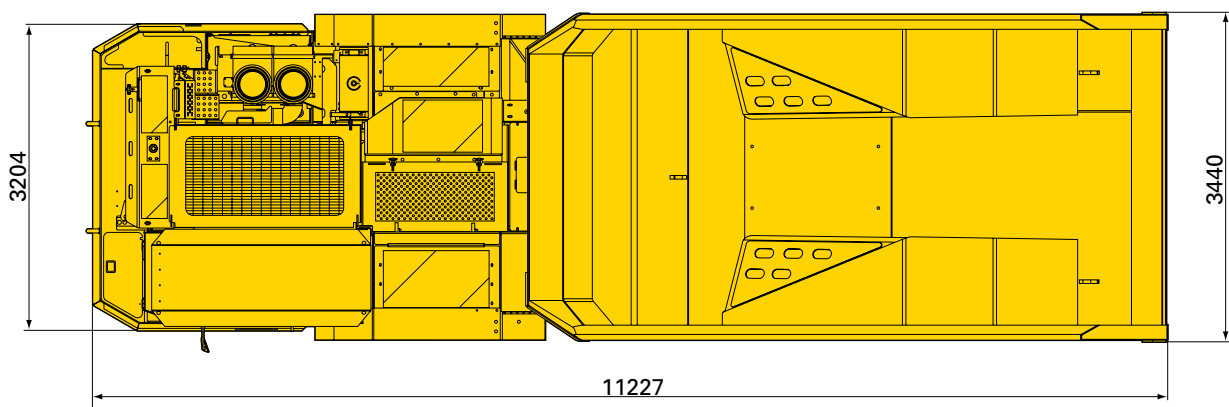

Top view

- Dimensions shown are based on standard vehicle configuration with 27 mm tyre deflection.
- All dimensions are shown in millimetres.



© Copyright 2007, Atlas Copco Rock Drills AB, Örebro, Sweden. Any unauthorized use or copying of the contents or any part thereof is prohibited. This applies in particular to trademarks, model denominations, part numbers and drawings. Illustrations and photos in this brochure may show equipment with optional extras. Specifications and equipment subjects to change without notice. Consult your Atlas Copco Customer Center for specific information.