

Caterpillar R2900G Bogger UL025



Make	Caterpillar		Model	R2900G	
Year		Hours	7272	As at	01/12/2019
Mileage			km	As at	
Serial/VIN	NLK00177		Engine Serial		
Details	<p>Caterpillar R2900G Loader Asset no UL025. Was fitted with and running ATX2200 Remote system. The ATX2200 controller is still on the machine while these parts have been removed and are not included as part of this machine when sold. ATX/ARX2200 Rotable RCT Part # 14404, Interface RCT Part # 8025, UPS RCT Part # 9841, Guidance unit RCT Part # 7280, Dual Teleremote RCT Part # 7026, Laser RCT Part # 12774, LED Lamp RCT Part # 12458, Mounting Pole RCT Part # 12633.. Offered for sale via online auction ex Site Nifty Copper Mine via Telfer Western Australia, running to drive on to buyers transport. See Google Maps link: https://goo.gl/maps/Xvaa3uBAFso9MP7A8</p>				
Asking price	AUD	Under review - call for pricing			
Ex site	Australia, Western Australia, Telfer				

**Service
history**

**For further details, to make an offer or book an inspection, contact
Global Equipment Solutions on Office: 08 9201 1142**













2.1.9 UL025, LHD CATERPILLAR R2900

- Guidance capable
- Cooler group replaced 6996 hours
- Table 1 includes all-time SMU and outstanding work orders
- Table 2 includes current component life.

Table 1. All-time SMU and outstanding work orders

Asset Number	Model	Serial Number	Current SMU reading (hrs)	All-time SMU
UL025	NLK R2900	NLK00177	7272	7272
Work Order	Description	Start Date	Status	Key/Section
4174715	FRONT REMOTE CAMERA	43792	I	RCT

Table 2. Current Component life

COMPONENT	Frequency	LAST CHANGE	HOURS TO GO
ENGINE	12000	2546	7274
TRANSMISSION	12000	0	4728
TORQUE CONVERTOR	12000	0	4728
Z-LINK	10000	0	2728
FRONT DIFF	10000	0	2728
FINAL DRIVE FRONT R/H	10000	0	2728
FINAL DRIVE FRONT L/H	10000	0	2728
REAR DIFF	10000	0	2728
FINAL DRIVE REAR R/H	10000	0	2728
FINAL DRIVE REAR L/H	10000	0	2728
H- FRAME	12000	0	4728

2.1.10 UL025 SUMMARY

Run to mid-life 16000 hours, Review PM Schedule

R2900G

Underground
Mining Loader



Engine

Engine Model	Cat® C15 ACERT™	
Gross Power – SAE J1995	321/333 kW	430/447 hp

Operating Specifications

Nominal Payload Capacity	17 200 kg	37,926 lb
Gross Machine Operating Weight	67 409 kg	148,611 lb

Bucket Capacities

Bucket Capacity – Std.	7.2 m ³	9.4 yd ³
------------------------	--------------------	---------------------

Engine

Engine Model	Cat C15 ACERT™	
Rated Power	1900/1800 rpm	
Gross Power – SAE J1995	321/333 kW	430/447 hp
Net Power – SAE J1349	290/302 kW	389/405 hp
Net Power – ISO 9249	288/300 kW	386/402 hp
Net Power – 80/1269/EEC	321/333 kW	430/447 hp
Bore	137.2 mm	5.4 in
Stroke	171.5 mm	6.8 in
Displacement	15.2 L	927.9 in ³

- Power ratings apply at a rated speed of 1900/1800 rpm when tested under the reference conditions for the specified standard.
- Ratings based on SAE J1995 standard air conditions of 25° C (77° F) and 100 kPa (29.61 Hg) barometer. Power based on fuel having API gravity of 35 at 16° C (60° F) and an LHV of 42 780 kJ/kg (18,390 BTU/lb) when engine used at 30° C (86° F).
- No engine derating required up to 591 m (1,938 ft) altitude.
- Compliant with U.S. Environmental Protection Agency Tier 3 emissions standards.

Operating Specifications

Nominal Payload Capacity	17 200 kg	37,926 lb
Gross Machine Operating Weight	67 409 kg	148,611 lb
Static Tipping Load Straight Ahead Lift Arms Horizontal	39 923 kg	88,015 lb
Static Tipping Load Full Turn Lift Arms Horizontal	34 069 kg	75,109 lb
Breakout Force (SAE)	27 346 kg	60,298 lb

Weights

Empty	50 209 kg	110,692 lb
Front Axle	23 057 kg	50,832 lb
Rear Axle	27 152 kg	59,860 lb
Loaded	67 409 kg	148,611 lb
Front Axle	50 220 kg	110,716 lb
Rear Axle	17 189 kg	37,895 lb

Transmission

Forward 1	5 km/h	3.1 mph
Forward 2	8.8 km/h	5.5 mph
Forward 3	15.2 km/h	9.4 mph
Forward 4	25.3 km/h	15.7 mph
Reverse 1	6.2 km/h	3.9 mph
Reverse 2	10.9 km/h	6.8 mph
Reverse 3	18.6 km/h	11.6 mph
Reverse 4	26.4 km/h	16.4 mph

Hydraulic Cycle Time

Raise	9.2 Seconds
Dump	3.4 Seconds
Lower, empty, float down	3.1 Seconds
Total Cycle Time	15.7 Seconds

Bucket Capacities

Bucket Capacity – Std.*	7.2 m ³	9.4 yd ³
Bucket Width (over cutting edge)	3154 mm	124.2 in
Bucket Capacity – Optional*	8.3 m ³	10.9 yd ³
Bucket Capacity – Optional*	8.9 m ³	11.6 yd ³

* High penetration bucket versions also available.

Turning Dimensions

Outside Clearance Radius**	7323 mm	288.3 in
Inner Clearance Radius**	3383 mm	133.2 in
Axle Oscillation	8°	
Articulation Angle	42.5°	

** Clearance dimensions are for reference only.

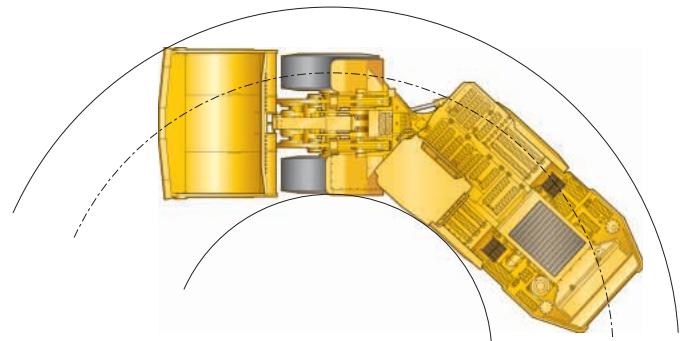

Dimensions

All dimensions are approximate.

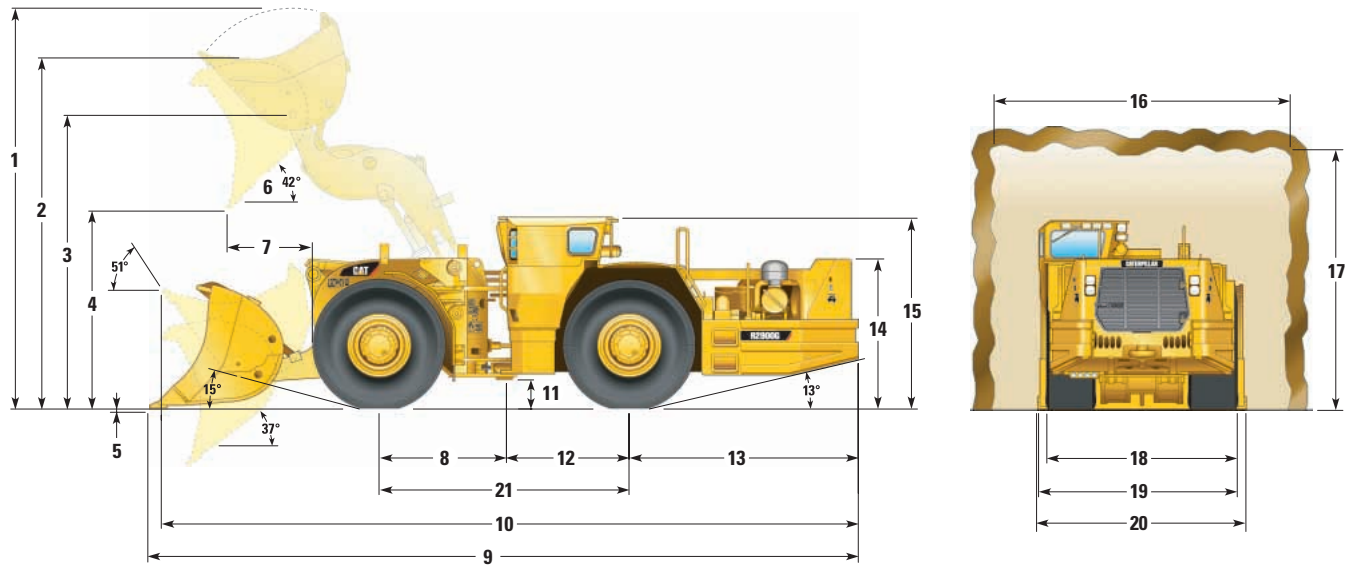

	249-4899 (Standard Bucket)*		249-4892*		249-4893*	
Bucket capacity	7.2 m ³	(9.4 yd ³)	8.3 m ³	(10.9 yd ³)	8.9 m ³	(11.6 yd ³)
Bucket width over cutting edge	3054 mm	(10 ft)	3154 mm	(10 ft 4 in)	3354 mm	(11 ft)
1 Overall height – bucket raised	6179 mm	(20 ft 3 in)	6232 mm	(20 ft 6 in)	6232 mm	(20 ft 6 in)
2 Maximum dump height	5427 mm	(17 ft 10 in)	5427 mm	(17 ft 10 in)	5427 mm	(17 ft 10 in)
3 Bucket pin height at maximum lift	4539 mm	(14 ft 11 in)	4539 mm	(14 ft 11 in)	4539 mm	(14 ft 11 in)
4 Dump clearance at maximum lift	2868 mm	(9 ft 5 in)	2735 mm	(9 ft)	2724 mm	(8 ft 11 in)
5 Digging depth	52 mm	(2 in)	65 mm	(2.6 in)	65 mm	(2.6 in)
6 Dump angle at maximum lift	42°		42°		42°	
7 Reach	1656 mm	(5 ft 5 in)	1803 mm	(5 ft 11 in)	1817 mm	(6 ft)
8 Centerline of front axle to centerline of hitch	1890 mm	(6 ft 2 in)	1890 mm	(6 ft 2 in)	1890 mm	(6 ft 2 in)
9 Overall length (digging)	11 302 mm	(37 ft 1 in)	11 507 mm	(37 ft 9 in)	11 525 mm	(37 ft 10 in)
10 Overall length (tramming)	10 949 mm	(35 ft 11 in)	11 073 mm	(36 ft 4 in)	11 083 mm	(36 ft 4 in)
11 Ground clearance	465 mm	(1 ft 6 in)	465 mm	(1 ft 6 in)	465 mm	(1 ft 6 in)
12 Centerline of back axle to centerline of hitch	1890 mm	(6 ft 2 in)	1890 mm	(6 ft 2 in)	1890 mm	(6 ft 2 in)
13 Length – rear axle to bumper	3572 mm	(11 ft 9 in)	3572 mm	(11 ft 9 in)	3572 mm	(11 ft 9 in)
14 Height to top of hood	2371 mm	(7 ft 9 in)	2371 mm	(7 ft 9 in)	2371 mm	(7 ft 9 in)
15 Height to top of ROPS	2886 mm	(9 ft 6 in)	2886 mm	(9 ft 6 in)	2886 mm	(9 ft 6 in)
16 Tunnel clearance width**	4500 mm	(14 ft 9 in)	4500 mm	(14 ft 9 in)	4500 mm	(14 ft 9 in)
17 Tunnel clearance height**	4500 mm	(14 ft 9 in)	4500 mm	(14 ft 9 in)	4500 mm	(14 ft 9 in)
18 Overall tire width	2898 mm	(9 ft 6 in)	2898 mm	(9 ft 6 in)	2898 mm	(9 ft 6 in)
19 Overall width excluding bucket	3010 mm	(9 ft 10 in)	3010 mm	(9 ft 10 in)	3010 mm	(9 ft 10 in)
20 Overall width including bucket	3176 mm	(10 ft 5 in)	3176 mm	(10 ft 5 in)	3176 mm	(10 ft 5 in)
21 Wheelbase	3780 mm	(12 ft 5 in)	3780 mm	(12 ft 5 in)	3780 mm	(12 ft 5 in)

*Dimensions shown with standard material bucket sizes. High penetration bucket versions also available.

**Clearance dimensions are for reference only.