

2011 Atlas Copco MT6020 Underground Truck UT015



Make	Atlas Copco		Model	MT6020		
Year	2011	Hours	32397		As at	01/12/2019
Mileage				km	As at	
Serial/VIN	AVO11X152			Engine Serial		
Details	2011 Atlas Copco MT6020 Truck Asset no UT015. Offered for sale via online auction ex Site Nifty Copper Mine via Telfer Western Australia, running to drive on to buyers transport. See Google Maps link: https://goo.gl/maps/Xvaa3uBAFso9MP7A8					
Asking price	AUD	Under review - call for pricing				
Ex site	Australia, Western Australia, Telfer					

Service history	
------------------------	--

**For further details, to make an offer or book an inspection, contact
Global Equipment Solutions on Office: 08 9201 1142**









2.1.25 UT015 UG HAUL ATLAS MT6020

- PCR - components replaced 2018
- Mid-life completed 10/3/2014 – 13375 hours
- Table 1 includes all-time SMU
- Table 2 includes current component life.

Table 1. All-time SMU and outstanding work orders

Asset Number	Model	Serial Number	Current SMU reading (hrs)	All-time SMU
UT015	MT6020	AVO-11X152	32397	32397

Table 2. Current Component life

COMPONENT	Frequency	LAST CHANGE	HOURS TO GO
ENGINE	12000	26561	6164
ENGINE MIDLIFE	6000	26561	164
UPBOX	8000	31309	6912
TRANSMISSION	8000	29059	4662
TRANSMISSION COOLER	6000	26561	164
DROPBOX	8000	29948	5551
R/H SUSPENSION CYL	6000	29823	3426
L/H SUSPENSION CYL	6000	30094	3697
RADIATOR CORE	16000	23942	7545
HYDRAULIC COOLER	6000	19926	-6471
FRONT DIFF	16000	30094	13697
FINAL DRIVE FRONT R/H	16000	30094	13697
FINAL DRIVE FRONT L/H	16000	30094	13697
REAR DIFF	16000	27717	11320
FINAL DRIVE REAR R/H	16000	27717	11320
FINAL DRIVE REAR L/H	16000	27717	11320
A-FRAME	6000	31672	5275

2.1.26 UT015 SUMMARY

Engine requires replacing – air cleaners knocked off resulting in dusted engine. Run to end of life, VMS fitted.

Specifications

Capacities		Motion times	
SAE regulations		Dump box	
Tramming capacity	60 000 kg	Dumping	15 seconds

Engine

- Cummins.....QSK19-C760, Tier 1/Stage I A
- Power Rating at 2100 rpm..... 567 kW/760 hp
- Maximum torque at 1300 rpm..... 3 084 Nm
- MSHA Part 7 ventilation rate TBA
- Ventilation particulate index TBA
- Rock Tough purifier and silencer.
- Dry type air cleaner.
- Exhaust heat protection.
- Remote engine oil drain.
- Cooling package with flat, round, mechanical radiator.

Transmission and converter

- Planetary, automatic 6 speeds forward/2 speeds reverse with integral single stage converter with automatic lock up.
- Allison.....M6610AR
- Up box: Power transmitted through a 1:1 gear ratio box.
- Drop box: Power transmitted through a 1:1 gear ratio box.

Axles

- Kessler 111
- Conventional front and rear differential.
- Front-axle oscillating suspension "A" frame with hydraulic suspension cylinders and accumulator cushioning.
- All wheel drive.

Brakes

- Fully enclosed, force cooled, multiple wet discs at each wheel end.
- Service/parking/emergency brakes SAHR
 - Hydraulic retarder.



The MT6020 is standard equipped with a rear vision camera. A small detail, but definitely worth viewing - is the standard equipped camera for improved operator's visibility.

Tyres

- Tubeless, steel radial, lug tread design for underground mine service.
- Dimensions 35/65, R33*
- * As applications and conditions vary, Atlas Copco recommends that the user consults with tyre suppliers to obtain the optimum tyre selection.

Suspension

- The suspension is a gas-hydraulic system for improved operator comfort and vehicle handling while minimizing frame stress.
- Suspension, max: 105 mm
 - Individual self leveling suspension.

Operator's compartment

- Forward facing seat.
- Cabin; MSHA-ISO ROPS/FOPS approved.
- Grammer seat with retractable seat belts.
- Airconditioner.
- Trainer seat.
- Back up video monitor.

Hydraulic system

- System pressure 20.7 MPa
- Hydraulic tank capacity 238 litres
- Filtration, return line 4.0 µm
- Heavy duty gear type pumps.
- Cylinders diameter:
 - Steer cylinders (2) 160 mm
 - Dump cylinders (2) 177.8 mm
 - Suspension cylinders (2) 125 mm

Electrical system

- Voltage, system start & accessories 24 V
- Alternator, high output 100 A
- Hydraulic warning system; temperature, hyd. oil level.
- Rock Tough projection lights.
- Isolation switch lockout.

Fuel

- Fuel tank capacity 644 litres
- Fuel consumption, full load 67 litres/hour
- Fuel filtration 10 µm
- Anti-siphon fuel supply.

Turning radius

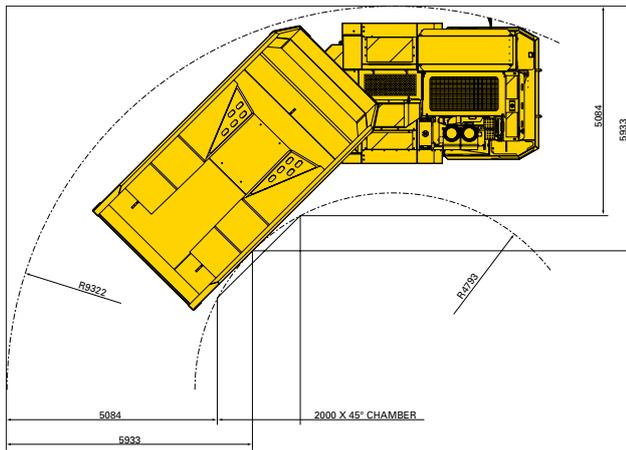

Recommended drift size

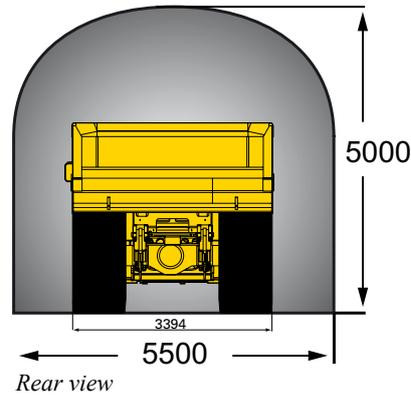

- Turning angle +/-42.5°.
- Dimensions shown are based on standard vehicle configuration with 27 mm tyre deflection.
- All dimensions are shown in millimetres.

Grade performance

NB. 3% rolling resistance assumed. Actual performance may vary depending on the application.

Standard configuration, box empty

Percent grade	0.0	2.0	4.0	6.0	8.0	10.0	12.0	14.0	16.0	18.0	20.0
Ratio					1:12	1:10	1:8	1:7			1:5
1st gear (km/h)	6.4	6.4	6.3	6.3	6.3	6.3	6.3	6.3	6.3	6.3	6.3
2nd gear (km/h)	9.5	9.5	9.4	9.4	9.4	9.4	9.3	9.3	9.3	9.3	9.2
3rd gear (km/h)	12.6	12.6	12.5	12.5	12.4	12.4	12.4	12.3	12.3	12.2	12.2
4th gear (km/h)	18.3	18.2	18.2	18.1	18.0	17.9	17.8	17.7	17.6	17.5	17.1
5th gear (km/h)	25.2	25.1	24.9	24.7	24.5	24.3	24.2	23.2	21.2		
6th gear (km/h)	37.5	37.1	36.7	36.3	35.6	30.9					

Standard configuration, box loaded

Percent grade	0.0	2.0	4.0	6.0	8.0	10.0	12.0	14.0	16.0	18.0	20.0
Ratio					1:12	1:10	1:8	1:7			1:5
1st gear (km/h)	6.3	6.3	6.3	6.2	6.2	6.2	6.2	6.1	6.1	6.1	6.0
2nd gear (km/h)	9.4	9.3	9.3	9.2	9.2	9.1	9.0	9.0	8.3	7.3	
3rd gear (km/h)	12.5	12.4	12.3	12.2	12.1	11.9	10.6				
4th gear (km/h)	18.1	17.9	17.6	17.2	13.5						
5th gear (km/h)	24.8	24.3	22.5								
6th gear (km/h)	36.5	31.7									

Optional equipment

Main frame

- Wheel chocks and chock brackets.
- Tele dump

Ergonomic

- KAB 555 seat W/retractable seatbelts.
- Heater

System

- Ansul dual bottle fire suppression with Engine kill.
- Electric hydraulic tank fill pump.
- Dual fuel filter.

- Lincoln auto lube with timer.
- Wiggins fast fuel-, transmission-, hydraulic- oil fill.

Electrical system

- Amber strobe light - power on.
- Load lights.
- Side light opposite operator.
- Tail and brake lights.
- Turn signals, front and rear.
- 24/12 V power converter.
- Loading camera.
- Battery heater, 120 V.
- Block heater, 120 V.
- Hydraulic oil heater, 120 V.

- Engine oil heater, 120 V.

- Diesel Filter with heater and water separation (7 micron).
- Fire extinguisher (20 LB)

Drive train

- Neutral brake apply.

Controls and instruments

- Blockout 5th and/or 6th gears.
- Emergency steering- accumulator type.
- Extended data gauge package.

Power unit

- Epoxy coated radiator.

Documentation

- LinkOne parts catalogue, CD.
- Parts and service manual - plasticised.

Parts kit

- 1 000 hour consumables.

Other

- Tool box.

Dump boxes

Dump box data		STD			
Material density (t/m ³)	1.8	2.0	2.2	2.4	
Volume, SEA struck (m ³)	30.4	26.6	24.1	21.7	
Volume, Semi-heaped (m ³)	33.3	29.7	27.3	25.0	
Volume, SAE heaped (m ³)	36.3	32.8	33.4	28.2	
Width, dump box (mm)	W	3 440	3440	3440	3440
Dump position: Box height, max (mm)	H1	6909	6842	6750	6689
Tramming position: Dump box height (mm)	H2	3462	3263	3122	2993
Dump position: Clearance (mm)	C	471	471	471	471

Dimensions and weights

Approximate net weight.....	43 900 kg
Axle load, front end.....	29 700 kg
Axle load, back end.....	14 200 kg

Standard equipped vehicle with empty box.

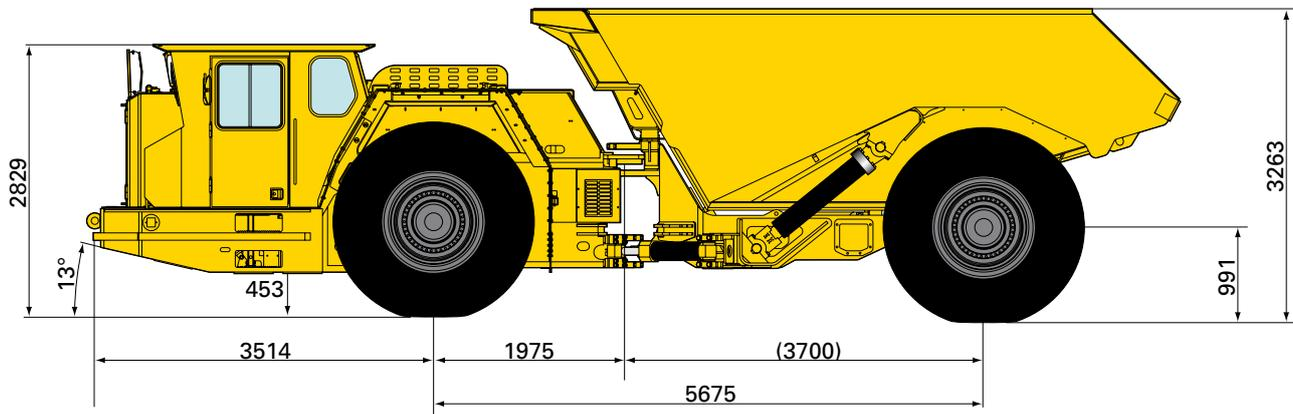

Side view

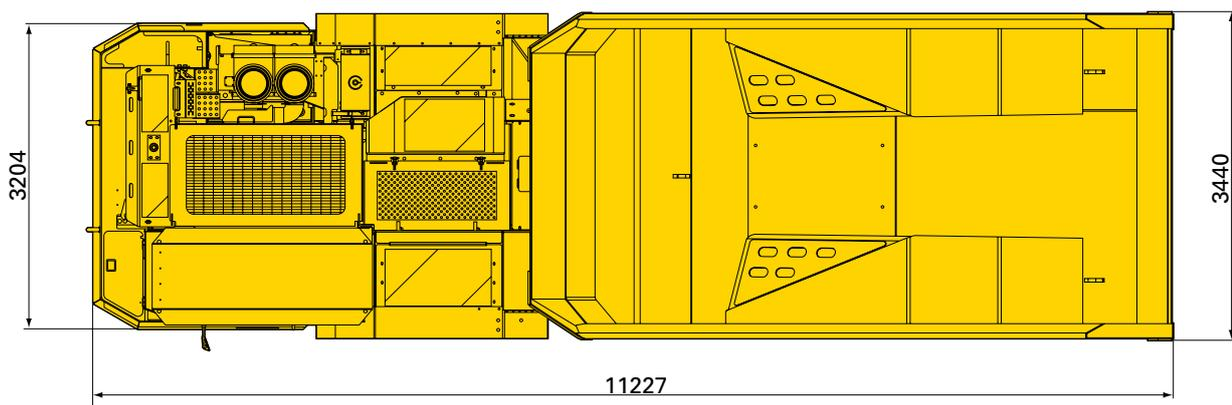

Top view

- Dimensions shown are based on standard vehicle configuration with 27 mm tyre deflection.
- All dimensions are shown in millimetres.